

*Model 3816/2*

# Line Impedance Stabilization Network (LISN)

User Manual

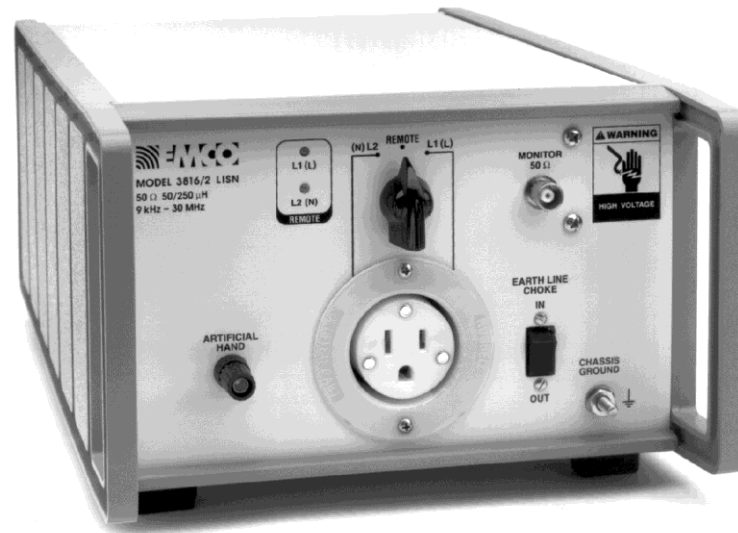

 **ETS·LINDGREN**<sup>®</sup>  
An ESCO Technologies Company

ETS-Lindgren Inc. reserves the right to make changes to any product described herein in order to improve function, design, or for any other reason. Nothing contained herein shall constitute ETS-Lindgren Inc. assuming any liability whatsoever arising out of the application or use of any product or circuit described herein. ETS-Lindgren Inc. does not convey any license under its patent rights or the rights of others.

**© Copyright 1999–2014 by ETS-Lindgren Inc. All Rights Reserved. No part of this document may be copied by any means without written permission from ETS-Lindgren Inc.**

Trademarks used in this document: The *ETS-Lindgren* logo is a registered trademark of ETS-Lindgren Inc.

**Revision Record | MANUAL 3816/2 | Part # 399198, Rev. C**

<b>Revision</b>	<b>Description</b>	<b>Date</b>
A	Initial Release	January, 1999
B	Rebrand; added <i>EC Declaration of Conformity</i>	July, 2010
C	Updated <i>Line Select Switch</i> information	July, 2014

# Table of Contents

<b>Notes, Cautions, and Warnings</b> .....	<b>v</b>
<b>1.0 Introduction</b> .....	<b>7</b>
Data.....	7
ETS-Lindgren Product Information Bulletin .....	8
<b>2.0 Maintenance</b> .....	<b>9</b>
Service Procedures .....	10
<b>3.0 Specifications</b> .....	<b>11</b>
Electrical Specifications .....	11
Physical Specifications .....	12
<b>4.0 Installation and Application</b> .....	<b>13</b>
Front Panel Connectors and Controls .....	14
BNC Connector.....	14
RF Ground.....	14
Earth Line Choke Switch.....	14
Artificial Hand.....	14
Line Select Switch.....	15
Back Panel Connectors .....	16
Power Input .....	16
RF Ground.....	16
<b>5.0 Schematic</b> .....	<b>17</b>
<b>Appendix A: Warranty</b> .....	<b>19</b>
<b>Appendix B: EC Declaration of Conformity</b> .....	<b>21</b>

This page intentionally left blank.

## Notes, Cautions, and Warnings

---

	<p><b>Note:</b> Denotes helpful information intended to provide tips for better use of the product.</p>
<p><b>CAUTION</b></p>	<p><b>Caution:</b> Denotes a hazard. Failure to follow instructions could result in minor personal injury and/or property damage. Included text gives proper procedures.</p>
<p><b>WARNING</b></p>	<p><b>Warning:</b> Denotes a hazard. Failure to follow instructions could result in SEVERE personal injury and/or property damage. Included text gives proper procedures.</p>



See the ETS-Lindgren *Product Information Bulletin* for safety, regulatory, and other product marking information.

This page intentionally left blank.

## 1.0 Introduction

---

The ETS-Lindgren **Model 3816/2 Line Impedance Stabilization Network (LISN)** is a two-channel low pass filter network designed to isolate the Equipment Under Test from an external power source while steering any radio frequency signals from the power line to a 50-ohm port.

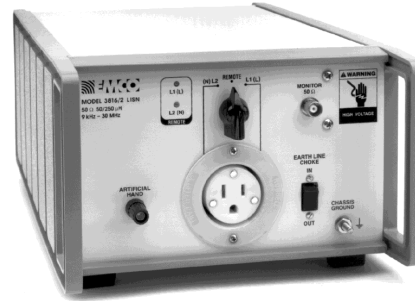

*Model 3816/2 Front View*

The conducted emissions measurements may be made in accordance with regulatory compliance standards.

### **Data**

---

Characterizations for each measurement port of the Model 3816/2 Line Impedance Stabilization Network (LISN) are included with the unit. The graphs provide individual plots of both impedance and insertion loss data.

A *Certificate of Calibration Conformance* is provided with each Model 3816/2.

## **ETS-Lindgren Product Information Bulletin**

---

See the ETS-Lindgren *Product Information Bulletin* included with your shipment for the following:

- Warranty information
- Safety, regulatory, and other product marking information
- Steps to receive your shipment
- Steps to return a component for service
- ETS-Lindgren calibration service
- ETS-Lindgren contact information



## 2.0 Maintenance

---

### WARNING



Only trained service personnel should perform adjustments and/or service procedures.

Inside the Model 3816/2 are LETHAL voltages with which you could come into contact. Capacitors inside the unit may still be CHARGED even when the unit is disconnected from power.

### CAUTION

Before performing any maintenance, follow the safety information in the ETS-Lindgren *Product Information Bulletin* included with your shipment.



Maintenance of the Model 3816/2 is limited to external components such as cables or connectors.

Clean the exterior of the cabinet using a damp cloth and mild cleaner. Always unplug the unit before cleaning.

To prevent electrical shock, do not remove cover.

If you have any questions concerning maintenance, contact ETS-Lindgren Customer Service.

## **Service Procedures**

---

For the steps to return a system or system component to ETS-Lindgren for service, see the *Product Information Bulletin* included with your shipment.

### 3.0 Specifications

#### Electrical Specifications

<b>Frequency Range:</b>	9 kHz–30 MHz (VDE 0876 specified curve $\pm$ 20%)
<b>Network Inductance:</b>	50 $\mu$ H / 250 $\mu$ H
<b>Network Impedance:</b>	50 $\Omega$
<b>Power Line Frequency:</b>	DC: 60 Hz
<b>Maximum Current:</b>	15 (16) amperes (as supplied)
<b>Maximum Voltage</b>	
<b>Line-to-Line</b>	460 volts AC RMS
<b>Line-to-Ground</b>	250 volts AC RMS
<b>Maximum AC Voltage</b>	
<b>3810/2NM:</b>	125 VAC 60 Hz
<b>3810/2BR:</b>	250 VAC 50 Hz
<b>3810/2SH:</b>	250 VAC 50 Hz
<b>3810/2AS:</b>	250 VAC 50 Hz
<b>Output Connectors</b>	
<b>3810/2NM:</b>	NEMA 5-15R
<b>3810/2BR:</b>	British BS1363
<b>3810/2SH:</b>	Schuko CEE 7/7
<b>3810/2AS:</b>	AS 3112
<b>Input Connector:</b>	IEC-320 Type 3-wire Inlet

<b>Environmental</b>	
<b>Installation:</b>	Indoor use only
<b>Altitude:</b>	15000 ft (4572 m) max
<b>Temperature:</b>	0°C to 40°C (32°F to 104°F)
<b>Relative Humidity:</b>	80% up to 31°C (87.8°F) decreasing linearly to 50% at 40°C (104°F)

### **Physical Specifications**

---

<b>Height:</b>	124 mm (4.9 in)
<b>Width:</b>	218 mm (8.6 in)
<b>Depth:</b>	381 mm (15.0 in)
<b>Weight:</b>	5.4 kg (12.0 lb)

## 4.0 Installation and Application

---

### CAUTION

Before connecting any components, follow the safety information in the ETS-Lindgren *Product Information Bulletin* included with your shipment.

### CAUTION

The Model 3816/2 is provided with resistors to help bleed off high voltage transients, but it is advisable to connect the input and output connectors to their proper power lines and loads before connecting the monitor port to the measurement instrumentation; otherwise, power surges or transients can damage the test instrumentation mixers or attenuators.

The Model 3816/2 Line Impedance Stabilization Network (LISN) is nominally designed for a 15-ampere current capacity, this rating may be increased to 16 amperes provided that the input and output connections are configured for these currents.

- Maximum line-to-line voltage must not exceed the 460 volts AC RMS.
- Maximum line-to-ground voltage must not exceed 250 volts AC RMS.

### WARNING

The safety ground should be connected first and disconnected last on the input side of the unit.



An RF ground stud is provided on the front panel and rear panel for bonding to the ground plane.

The input power connection is made through a three-wire power cord utilizing the accepted international color code. The input power cord opening is sized to accept a standard electrical conduit fitting or strain relief (supplied). An internally-mounted terminal strip provides the input connection point. When connecting the conduit, disconnect the power cord from the terminal strip and remove it.

## **Front Panel Connectors and Controls**

---

### **BNC CONNECTOR**

Connect the Model 3816/2 to the spectrum analyzer or EMI receiver through the BNC connector.

### **RF GROUND**

The Model 3816/2 is provided with an RF bonding stud on both the front and rear panels. The unit should be bonded to a ground plane in normal operation.

### **EARTH LINE CHOKE SWITCH**

The safety ground isolation choke selector switch switches the 1.6 mH earth line choke IN and OUT of the safety ground circuit. The ground choke is designed and manufactured with sufficient capacity to conduct the maximum current rating of the Model 3816/2 and at no time is the safety ground of the unit compromised. The earth line choke avoids a double RF ground connection (safety ground and measurement ground) in the conducted emissions test setup.

### **ARTIFICIAL HAND**

In conformance with EN55014 and BS800, the artificial hand connection is used to test handheld equipment that is provided without earth connections.

## LINE SELECT SWITCH

Select the line to be monitored by the three-position selector switch. The line not selected is internally terminated into 50 ohms. When using the remote (center) position, connect the monitored line to the 9-pin connector on the rear panel. Control signals are low-level 5 volt DC.

- To monitor Line L1, apply +5VDC to pin 1 of the 9-pin connector.
- To monitor L2, apply +5VDC to pin 3.
- Should +5VDC be applied to both pins, the first pin to receive the control signal will be selected.
- As with manual selection, the line not selected is terminated into 50  $\Omega$ .
- Pin 2 of the 9-pin connector is control common.

### CAUTION

**Although the unit is provided with resistors to help bleed off high voltage transients, connect the input and output connectors to their proper power lines and loads before connecting the monitor port to the measurement instrument. Otherwise, you may damage the mixers or attenuators of the test instrumentation due to power surges or transients.**

Switching between the two lines will not generate transients. Remove the power source first when disconnecting power.

## **Back Panel Connectors**

---

### **POWER INPUT**

The input power connection is made through a jacketed three-conductor power cable. This three-conductor power cable is rated at 16 amperes maximum. In case of emergency, power can be removed from the unit by disconnecting the Model 3816/2 input power plug from the power mains. Alternately, a properly rated circuit breaker or switch which removes mains power from the unit can be installed in proximity to the unit.

### **RF GROUND**

See description on page 14.



## 5.0 Schematic

---



- Resistance values shown in ohms.
- Ground choke select switch (S1) shown in the IN position.
- Line monitor select switch (S2) shown in the L2 (NTL) position.
- NEMA type output connector shown.

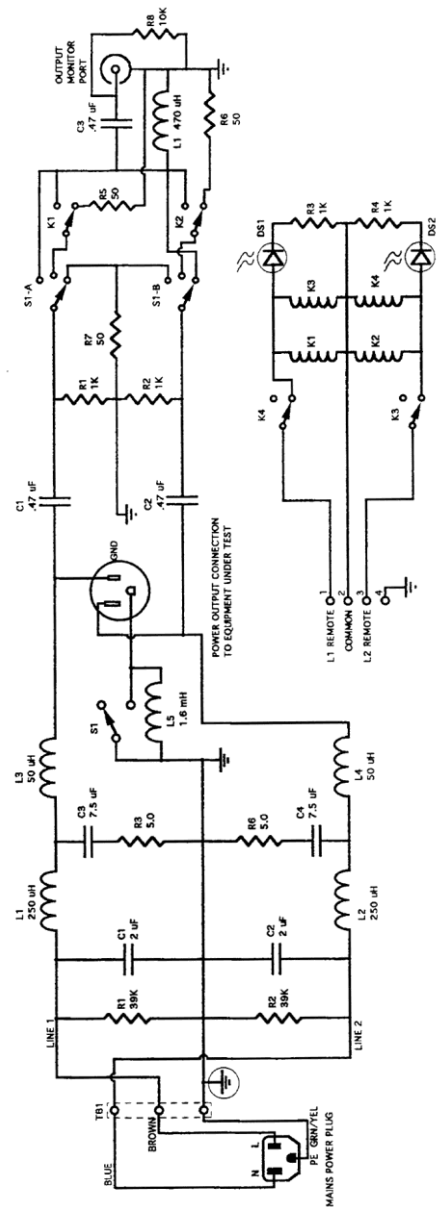

## Appendix A: Warranty

---



See the *Product Information Bulletin* included with your shipment for the complete ETS-Lindgren warranty for your Model 3816/2.

### DURATION OF WARRANTIES FOR MODEL 3816/2

All product warranties, except the warranty of title, and all remedies for warranty failures are limited to two years.

Product Warranted	Duration of Warranty Period
Model 3816/2 Line Impedance Stabilization Network (LISN)	2 Years

This page intentionally left blank.

## Appendix B: EC Declaration of Conformity



### EUROPEAN COMMUNITY DECLARATION OF CONFORMITY

The EC Declaration of Conformity is the method by which EMC Test Systems, L.P. declares that the equipment listed on this document complies with the EMC directive.

**Factory:**

EMC Test Systems, L.P.  
P.O. Box 80589  
Austin, Texas USA  
78708-0589

**Issued by:**

EMC Test Systems, L.P.  
P.O. Box 80589  
Austin, Texas USA  
78708-0589

**The products manufactured under the EMCO product name and listed below are eligible to bear the EC Mark:**

Model 3816/2SH Line Impedance Stabilization Network  
Model 3816/2BR Line Impedance Stabilization Network  
Model 3816/2NM Line Impedance Stabilization Network  
Model 3816/2AS Line Impedance Stabilization Network

**Applicable Requirements:**

<u>Standard</u>	<u>Criteria</u>
IEC1010	Safety requirements for electrical equipment for measurement, control and laboratory use
EN55022	Passive device. EMC testing is not required.

**Authorized Signatories**

  
Bruce Butler, General Manager

  
Charles Garrison, Quality Assurance

  
James C. Psencik, Engineering Mgr.

**Date of Declaration**

The authorizing signature on the EC Declaration of Conformity document authorizes EMC Test Systems, L.P. to affix the CE mark to the indicated product. CE marks placed on these products will be distinct and visible. Other marks or inscriptions liable to be confused with the CE mark will not be affixed to these products. EMC Test Systems, L.P. has ensured that appropriate documentation shall remain available on premises for inspection and validation purposes for a period of no less than 10 years.