

HI-4450/FP2080 FP4080/FP5080

Isotropic Electric Field Probe User's Manual

Declaration of Conformity

ETS-Lindgren, L.P.
1301 Arrow Point Drive
Cedar Park, TX 78613
USA



Declares that the HOLADAY product described in this instruction manual is in compliance with: EN EMC Directive 86/336/EEC, EN50082-1, EN55011

ETS-Lindgren, L.P.
(Formerly Holaday Industries, Inc.)



ETS-Lindgren L.P., reserves the right to make changes to any product described herein in order to improve function, design, or for any other reason. Nothing contained herein shall constitute ETS-Lindgren L.P. assuming any liability whatsoever arising out of the application or use of any product or circuit described herein. ETS-Lindgren L.P. does not convey any license under its patent rights or the rights of others.

© Copyright 2005 by ETS-Lindgren L.P. All Rights Reserved.

No part of this document may be copied by any means without written permission from ETS-Lindgren L.P.

EMAIL & INTERNET ADDRESSES

support@ets-lindgren.com
http://www.ets-lindgren.com

USA

1301 Arrow Point Dr., Cedar Park TX 78613 USA
P.O. Box 80589, Austin, TX 78708-0589 USA
Tel 512.531.6400
Fax 512.531.6500

FINLAND

Mekaanikontie 1, 27510, Eura, Finland
Tel 358.2.838.3300
Fax 358.2.865.1233

JAPAN

4-2-6, Kohinata
Bunkyo-ku
Tokyo 112-0006 JAPAN
Phone + 81 3 3813 7100
Fax + 81 3 3813 8068

CHINA

1917-1918 Xue Zhixuan Building
No 16 Xue Qing Road
Haidian District
Beijing Postcode: 100083 CHINA
Phone + 86 010 82755304
Fax + 86 010 82755307

REVISION RECORD

HI-4450/FP2080/FP4080/FP5080, MANUAL, Part #600057

Revision	Description	Date
	Initial Release	October, 1993
A	Isotropy Spec	October, 1994
B	Changed Battery Charger	June, 1997
C	Added CE Label	June, 1997
D	Changed Charger Spec	August, 1999
E	Changed Area Code	February, 2000
F	Revised	June, 2005

This page intentionally left blank.

Table of Contents

1.	Introduction.....	7
	Description	7
	Specifications	8
2.	Getting Started.....	11
	Unpacking and Acceptance	11
	Probe	11
	XMIT/RCV	12
	ARM/OFF	13
	Charger	13
	Battery	13
	Battery Charging	13
	Charging Procedure.....	14
	Battery Tips.....	14
3.	Operation.....	15
	System Theory	15
	Probe Operation	17
	Probe Power Supply.....	18
	Zeroing.....	18
	Application Considerations	18
	Out-of-Band Considerations	18
	Resolution Limitations.....	19
	Probe Support Structures	19
4.	Maintenance.....	21
	Maintenance Recommendations.....	21
	Upgrade Policies	21
	Return Procedures	21
	Periodic/Preventive Maintenance.....	22
	Parts Information	23
5.	Warranty Policy for Electromagnetic Isotropic Field Monitoring Components	25
	Scope and Duration of Warranties	25
	Warranty Exclusions.....	26
	Buyer's Remedies	27
6.	Appendix A: HI-4450/FP2080/FP4080/FP5080 Error Codes	29
	Probe Error Output.....	29
7.	APPENDIX B: HI-4450/FP2080/FP4080/FP5080 Operating Protocols	31

Communication Protocol 31
Information Transfer Protocol..... 31
Command Structure 31
Commands 32
Probe Output 34
8. Appendix C: Battery Charger User Manual ... 35
 Series 491198-36 37
 User's Manual 37
JAPAN 38
CHINA 38
 Warning 41
 NEVER attempt to change the fuse with the battery
 charger plugged in. 51
 NEVER attempt to recharge a non-rechargeable
 battery. 52

1. INTRODUCTION

DESCRIPTION

The HI-4450/FP2080/FP4080/FP5080 Electric Field Probes embody the latest innovations in isotropic sensor design and low noise, miniaturized electronics. The HI-4450/FP2080/FP4080/FP5080 probes are fully intelligent sensor enabling fast and accurate EMF measurements with industry-leading performance specifications. Optical coupling to a variety of readout options makes this new probe ideally suited for a wide range of field monitoring applications. The HI-4450/FP2080/FP4080/FP5080 probes are excellent tools for electric field mapping, RADHAZ measurements and EMC field monitoring.

The basic HI-4450/FP2080/FP4080/FP5080 probes are shipped complete with a 10 meter fiber extension cable, a carrying case, battery charger and connectors for extending the optic cable.

The HI-4450/FP2080/FP4080/FP5080 probe assembly consists of a spherical casing, containing the sensor, which is mounted on one end of a shaft; the other end of the shaft is attached to an extrusion that houses the electronics (Figure 1). The sensor and electronics housing operate-and are calibrated-as a unit.

The HI-4450/FP2080/FP4080/FP5080 measures the field strength in each of three axes. It performs a vector addition calculation on the readings and sends the resultant to the receiver via a fiber optic cable. Frequency response of the HI-4450/FP2080/FP4080/FP5080 is 80 MHz to 40 GHz; dynamic range is 1 to 300 Volts per meter (V/m).



Figure 1: FP 5080 Isotropic Electric Field Probe

SPECIFICATIONS

Dynamic Range:	1 to 300 Volts/meter (V/m)	
Ranges:	10, 30, 100, 300 V/m full scale	
Frequency Response:	80 MHz to 26 GHz \pm 1.5 dB	
	26 GHz to 40.0 GHz \pm 3.0 dB	
Linearity:	\pm 0.5 dB full scale (F.S.): \pm 2 least significant bits (LSB's) of A/D converter	

Isotropic Electric Field Probe

Isotropy:	± 1.2 dB	
Average Overload:	6 times full scale (each range)	
Environmental:	Operating Temperature:	10°C to 40°C (50°F to 104°F)
	Humidity:	5% to 95% relative humidity, non-condensing
Fiber Optic Cable Connectors:	Standard FSMA	
Battery:	3.6 VDC, 1400 mA-h rechargeable Nickel-Cadmium (NiCd)	
Battery Charger:	115/230 VAC, approximately 1 hr	
Battery Life:	17 Hrs continuous (full charge)	
Probe Mount:	¼--20 UNC tapped hole (internal thread) in base of probe	
Size:	Length (including electronics housing):	432 mm (17.0 in)
	Probe diameter:	102 mm (4.0 in)
	Weight:	0.54 Kg (19 oz.)
Optional Equipment:	See Table 2	

This page intentionally left blank.

2. GETTING STARTED

UNPACKING AND ACCEPTANCE

Step 1. Upon delivery of your order, inspect the shipping container(s) for evidence of damage. Record any damage on the delivery receipt before signing. In case of concealed damage or loss, retain the packing materials for inspection by the carrier.

Step 2. Remove the probe from its shipping containers. Save the boxes and any protective packing materials for future use.

Step 3. Check all materials against the packing list to verify that the equipment received matches what was ordered. If you find any discrepancies, note them and call ETS-Lindgren Customer Service for further instructions.

Be sure that you are satisfied with the contents of your order and the condition of your equipment before installing the probe.

PROBE

A switch, two fiber optic connectors and a battery charger connector are mounted on the HI-4450/FP2080/FP4080/FP5080 electronics housing (Figure 2).

XMIT/RCV

The fiber optic cable assembly from the receiver is attached to the probe via two connectors. The cables are color-coded white for XMIT, yellow for RCV. Identically colored dots are located on the electronics housing adjacent to these connectors. Be sure that each cable is attached to the proper probe connector.

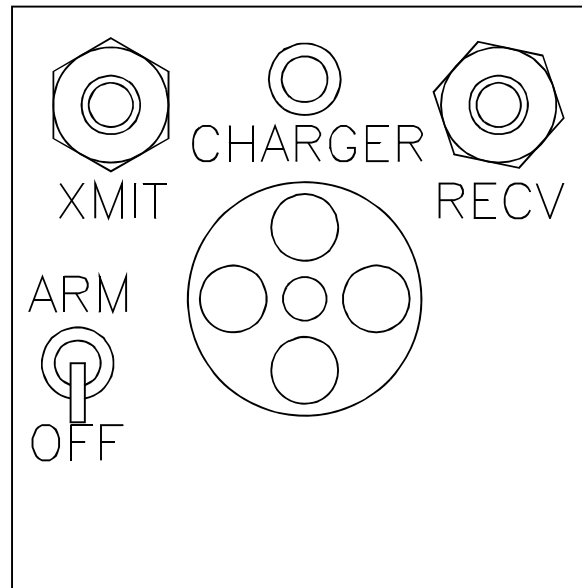

Figure 2: Switch and Connectors

When the fiber optic cables are not attached, always cover the probe connectors with the protective plastic covers supplied with the unit, or with similar material. This prevents dirt or other contaminants from entering the connector and causing communication problems.

ARM/OFF

The ARM/OFF switch activates and deactivates the probe. In the ARM position, its internal 3.6 VDC NiCd battery powers the probe: in the OFF position, the probe is inactive. To prolong battery life, set the ARM/OFF switch to OFF at the end of a test sequence or when the probe is not in use.

CHARGER

A standard fast charger is supplied with the HI-4450/FP2080/FP4080/FP5080. When charging is complete, the fast charger acts as a trickle charger. The battery can be left on this maintenance mode indefinitely and its performance will not degrade.

BATTERY

The NiCd battery provides up to 17 hours of probe operation when fully charged.

BATTERY CHARGING

Each HI-4450/FP2080/FP4080/FP5080 probe contains a rechargeable nickel-cadmium (NiCd) battery. A fully-charged battery (nominal output voltage of 3.6 VDC) provides up to 17 hours of continuous operation.

NOTE: ETS-Lindgren charges the internal NiCd battery of the HI-4450/FP2080/FP4080/FP5080 at the factory in order to calibrate the probe prior to shipment. While every effort is made to ensure that your probe arrives ready to use, we cannot guarantee that this will be the case. Always check the condition of the probe's battery prior to making any measurements.

CHARGING PROCEDURE

Step 1. Plug the charger into a suitable AC source.

Step 2. Set the probe switch to OFF. Insert the plug on the charger cable into the probe's CHARGER jack.

Step 3. The battery is now charging. This may take approximately one hour, depending on how deeply the batteries are discharged. When charging is complete, the charger automatically goes into a trickle charge and will continue to do so until the probe is disconnected.

BATTERY TIPS

NiCd batteries have several characteristics that can affect both their performance and operating life. The following tips advise you how to take advantage of these characteristics to get the most out of your probe's battery.

- Although NiCd batteries are rated for operation in temperatures from -20°C to +65°C (-4 °F to +140 °F), operating the probe in extreme temperatures will reduce operating time significantly. The optimum operating temperature range for these batteries is +20°C to +30°C (+68°F to +86°F).
- The battery in the HI-4450/FP2080/FP4080/FP5080 probe does not require periodic "deep discharges" to reverse the capacity-depleting "memory effect" caused by repeated shallow discharges; however, undercharging can reduce battery capacity. Therefore, after the charging procedure is complete, be sure that the battery is fully charged before resuming field operation.
- If the battery exhibits low terminal voltage during charging, or if it appears unable to acquire or maintain an appreciable charge, individual cells in the battery may be shorted or damaged. If, for any reason, your battery needs replacement, contact ETS-Lindgren Customer Service for assistance.

3. OPERATION

This section discusses the theory of operation and the functions of the HI-4450/FP2080/FP4080/FP5080 Isotropic Electric Field Probe. A high-level block diagram (Figure 3) is included to aid the discussion. The objective is to provide information enhancing user understanding of the design of this probe.

SYSTEM THEORY

The HI-4450/FP2080/FP4080/FP5080 Broadband Isotropic Electric Field Probe utilizes a microprocessor for intelligent operation and control. The probe's self-contained power supply employs a 3.6 VDC NiCd battery, which provides up to 17 hours of continuous operation.

For each axis, the probe measures the radio frequency signal level and generates a linearized reading of the measurement. A vector addition is performed on these three readings: the result is transmitted to the readout over glass fiber optic cables. See "Probe Operation" below for a more detailed explanation of the functioning of the HI-4450/FP2080/FP4080/FP5080.

The probe relays data to the readout via either a short form or long form output word. See Appendix B for details on both output word formats.

For some applications, you may use any computer with an RS232 serial port to communicate directly with the HI-4450/FP2080/FP4080/FP5080 via ETS-Lindgren's optional HI-4413P Fiber Optic/RS232 Interface.

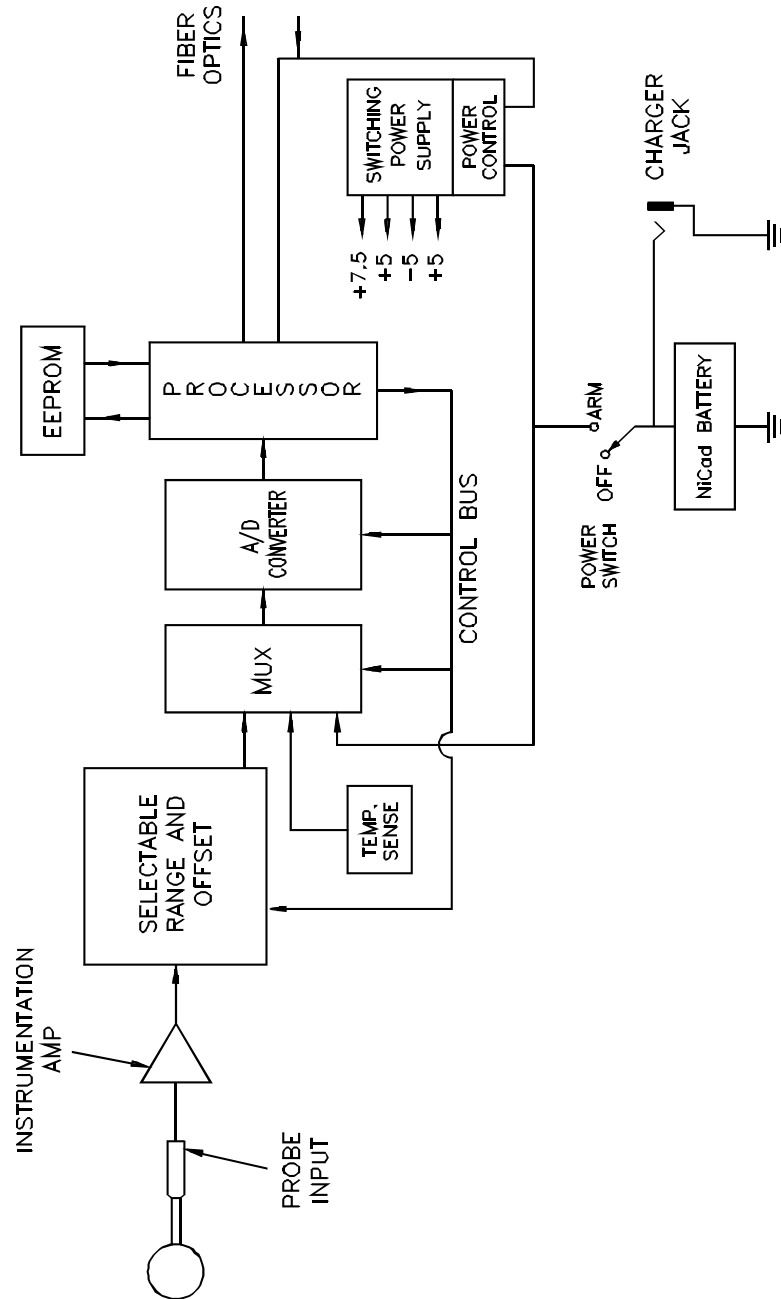

Figure 3: Operation Block Diagram

PROBE OPERATION

Receiver commands to the probe consist of the following:

- Sending reading
- Switch range
- Read battery voltage
- Zero
- Read temperature
- Enable axis
- Set sleep timer

The signal flow within the probe is shown in the block diagram.

To measure field strength, three mutually orthogonal dipole antennas (one per axis) are used to provide an isotropic response to the ambient field. The signal from each axis is fed to a Schottky diode detector operating in its Square-Law region. After filtering, the signals generated by each axis are added vectorially: the result is fed to the instrumentation amplifier, whose output feeds the selectable range/offset stage.

NOTE: The HI-4450/FP2080/FP4080/FP5080 does not allow the option of measuring on an individual axis: all three axes are active at all times. Consequently, the change axis commands have no effect.

For each of the four ranges, the selectable range and offset stage provides a coarse analog zero for the measured signal. The output of the range/offset stage is fed to the A/D multiplexer, then to the analog-to-digital (A/D) converter itself.

After acquiring the composite three-axis signal, the microprocessor commands the A/D multiplexer to read the battery voltage and temperature sensing lines.

Data from the A/D converter is fed to the microprocessor, which transmits it to the receiver.

The EEPROM stores all calibration data for the probe.

PROBE POWER SUPPLY

A sealed rechargeable 3.6 VDC NiCd battery, which drives both the analog and digital power supplies, powers the HI-4450/FP2080/FP4080/FP5080 probe; separate power sources provide isolation between the analog and digital circuitry. With the probe switch in the ARM position, battery voltage is applied to the power switch, which routes this voltage to the power supply, enabling the microprocessor.

ZEROING

When the receiver sends a zero command, the probe must be in a zero field environment. This is because the zero command causes the multiplexer (via the processor) to perform a normal read cycle on the composite axis signal. This procedure is executed for all ranges. When the processor receives all the zero-field values, it stores them in a special register; these values are subtracted from all subsequent measurements. Therefore, a probe that is zeroed while it is not in a zero field environment will give erroneous readings.

NOTE: The probe uses volatile random access memory (RAM) to store the zero values. If the power to the probe is cycled, the zero values will be lost.

APPLICATION CONSIDERATIONS

The following subsections contain information designed to help you maximize the effectiveness of the HI-4450/FP2080/FP4080/FP5080.

OUT-OF-BAND CONSIDERATIONS

Although the HI-4450/FP2080/FP4080/FP5080 is nominally rated for operation from 80 MHz to 40 GHz, it responds to signals both above and below these frequencies. Such responses must be taken into account when performing certain operations, such as zeroing.

Isotropic Electric Field Probe

On the lower end, the HI-4450/FP2080/FP4080/FP5080 can exhibit significant response to frequencies below 80 MHz. Such out-of-band responses pose a problem when zeroing the unit, since that operation obviously assumes a zero field condition. At the upper end, similar problems can occur. The specified upper operating limit for this probe is 40 GHz. Above this limit there will be some response, though it will not be consistent or predictable. Any probe response to out-of-band frequencies must be compensated for when zeroing the probe.

RESOLUTION LIMITATIONS

Limitations in probe resolution may result in a non-zero reading when the receiver is zeroed. If this occurs, it does not necessarily mean either that there is a problem with the receiver or that your readings are inaccurate. Receiver linearity is specified as + 0.5 dB full scale; in addition, the variance of the A/D converter is + 2 least significant bits. When using the most sensitive range on a given probe, these specifications create the possibility that, under zero field conditions, the receiver may display a non-zero value.

PROBE SUPPORT STRUCTURES

It is very important to keep conductive objects away from the HI-4450/FP2080/FP4080/FP5080. Any such objects in the proximity of the probe may distort the field and compromise measurement accuracy. If your application requires measurements from a fixed position, always mount the probe on a non-metallic platform, using non-metallic screws.

This page intentionally left blank.

4. MAINTENANCE

This section explains which maintenance tasks can be performed by the user. It also provides information regarding replacement and optional parts. If you have any questions concerning probe maintenance, consult ETS-Lindgren Customer Service.

MAINTENANCE RECOMMENDATIONS

Maintenance of the HI-4450/FP2080/FP4080/FP5080 probe is limited to external components such as cables or connectors.

Any calibration or maintenance task that requires probe disassembly should be performed at the factory. Check with ETS-Lindgren Customer Service (+1-512-531-6400) before opening the unit to avoid problems with your probe's warranty.

NOTE: Opening the probe enclosure may void your warranty. If your system is still under warranty, contact ETS-Lindgren Customer Service before performing any maintenance inside the probe.

UPGRADE POLICIES

Periodically, probes are upgraded to enhance functionality. These upgrades are commonly announced through ETS-Lindgren Engineering Bulletins.

RETURN PROCEDURES

To return a system or system component, use the following procedure.

Step 1. Contact ETS-Lindgren Customer Service (+1-512-531-6400) to obtain an SRO, Service Request Order.

Step 2. Briefly describe the problem in writing. Give details regarding the observed symptom(s) or error codes, and whether the problem is constant or intermittent in nature. Please include the date(s), the service representative you spoke with, and the

nature of the conversation. Include the serial number of the item being returned.

Step 3. Package the system or component carefully. Use the original packing boxes and materials, if possible.

NOTE: If your probe is calibrated in accordance with MIL-Std-45662A, it is to your benefit to retain the original shipping box and packing materials. One of the criteria for certifying a calibration to MIL standards requires ETS-Lindgren to always ship equipment in the specified packaging. When a MIL Standard instrument is sent to ETS-Lindgren in other packaging, we must replace it with the specified packaging materials for return shipment. **YOU WILL BE BILLED FOR THE NEW PACKAGING.**

If the probe is under warranty, refer to the Limited Warranty section of this manual for additional information about your return.

PERIODIC/PREVENTIVE MAINTENANCE

The HI-4450/FP2080/FP4080/FP5080 probe assembly (sensor and electronics housing) requires an annual calibration to verify that they are performing within specifications. ETS-Lindgren service personnel may perform this calibration at the factory. Return your probe(s), using the original packing materials (if possible), to:

ETS-Lindgren
Attn. Service Department
1301 Arrow Point Drive
Cedar Park, Texas, USA 78613

PARTS INFORMATION

Use the following tables for ordering replacement (Table 1) or optional (Table 2) parts for HI-4450/FP2080/FP4080/FP5080 probes.

Part Description (Replacement Parts)	Part Number
Battery Pack, 3.6 VDC, Rechargeable	H-491038
Standard Fast Charger (115/230 Volt)	H-491198-36
Cable, Fiber Optic, Glass (where xx indicates length in meters)	H-491106-xx
Probe Cover (2 Required)	H-470286A
Handle Assembly	H-491073
HI-4450/FP2080/FP4080/FP5080 User's Manual	H-600057

Table 1. Replacement Parts List

Part Description (Optional Parts)	Part Number
Probe Support, HI- 4450/FP2080/FP4080/FP5080	H-490984
Tripod, Dielectric, HI- 4450/FP2080/FP4080/FP5080	H-491000
Fiber Optic/RS232 Interface	HI-4413P
Probe Stand	H-491269
Graphical EMF Readout	HI-4460
Numeric EMF Readout	HI-4416
Field Monitor	FM5004

Table 2. Optional Parts List

This page intentionally left blank.

5. WARRANTY POLICY FOR ELECTROMAGNETIC ISOTROPIC FIELD MONITORING COMPONENTS

SCOPE AND DURATION OF WARRANTIES

Seller warrants to Buyer that the Holaday Brand Products to be delivered hereunder will be (1) free from defects in material, manufacturing workmanship, and title, and (2) conform to the Seller's applicable product descriptions and specifications, if any, contained in or attached to Seller's quotation. If no product descriptions or specifications are contained in or attached to the quotation, Seller's applicable product descriptions and specifications in effect on the date of shipment shall apply. The criteria for all testing shall be Seller's applicable product specifications utilizing factory-specified calibration and test procedures and instruments.

All product warranties, except the warranty of title, and all remedies for warranty failures are limited in time as shown in the table below.

<u>Product Warranted</u>	<u>Duration of Warranty Period</u>
FM5004	3 Years
HI-6005	3 Years
HI-6001	3 Years
HI-4450	3 Years
FP-4080	3 Years
FP-5000	3 Years
FP-2080	3 Years
HI-4453	3 Years
FP-4083	3 Years
FP-5083	3 Years
FP-2083	3 Years
FP-5080	3 Years
FP-4000	3 Years
FP-2000	3 Years
HI-4422	3 Years

Any product or part furnished to Buyer during the warranty period to correct a warranty failure shall be warranted to the extent of the unexpired term of the warranty applicable to the repaired or replaced product.

The warranty period shall commence on the date the product is delivered to Buyer; however, if Seller assembles the product, or provides technical direction of such assembly, the warranty period for such product shall commence on the date the assembly of the product is complete. Notwithstanding the foregoing, in the event that the assembly is delayed for a total of thirty (30) days or more from the date of delivery for any reason or reasons for which Seller is not responsible, the warranty period for such product may, at Seller's options, commence on the thirtieth (30th) day from the date such product is delivered to Buyer. Buyer shall promptly inspect all products upon delivery. No claims for shortages will be allowed unless shortages are reported to Seller in writing within ten (10) days after delivery. No other claims against Seller will be allowed unless asserted in writing within thirty (30) days after delivery (or assembly if the products are to be assembled by Seller) or, in the case of alleged breach of warranty, within the applicable warranty period.

WARRANTY EXCLUSIONS

Except as set forth in any applicable patent indemnity, the foregoing warranties are exclusive and in lieu of all other warranties, whether written, oral, express, implied, or statutory. EXCEPT AS EXPRESSLY STATED ABOVE, SELLER MAKES NO WARRANTY, EXPRESS OR IMPLIED, BY STATUTE OR OTHERWISE, WHETHER OF MERCHANTABILITY OR FITNESS FOR ANY PARTICULAR PURPOSE OR USE OR OTHERWISE ON THE PRODUCTS, OR ON ANY PARTS OR LABOR FURNISHED DURING THE SALE, DELIVERY OR SERVICING OF THE PRODUCTS. THERE ARE NO WARRANTIES THAT EXTEND BEYOND THE DESCRIPTION ON THE FACE HEREOF.

Warranty coverage does not include any defect or performance deficiency (including failure to conform to product descriptions or specifications) which results, in whole or in part, from (1) negligent storage or handling of the product by Buyer, its employees, agents, or contractors, (2) failure of Buyer to prepare the site or provide an operating environmental condition in compliance with any applicable instructions or recommendations of Seller, (3) absence of any product, component, or accessory recommended by Seller but omitted at Buyer's direction, (4) any design, specification, or instruction furnished by Buyer, its

Isotropic Electric Field Probe

employees, agents or contractors, (5) any alteration of the product by persons other than Seller, (6) combining Seller's product with any product furnished by others, (7) combining incompatible products of Seller, (8) interference with the radio frequency fields due to conditions or causes outside the product as furnished by Seller, (9) improper or extraordinary use of the product, or failure to comply with any applicable instructions or recommendations of Seller, or (10) acts of God, acts of civil or military authority, fires, floods, strikes or other labor disturbances, war, riot, or any other causes beyond the reasonable control of Seller. This warranty does not cover batteries or any item that is designed to be consumable. Seller does not warranty products of others, which are not included in Seller's published price lists.

BUYER'S REMEDIES

If Seller determines that any product fails to meet any warranty during the applicable warranty period, Seller shall correct any such failure by either, at its option, repairing, adjusting, or replacing without charge to Buyer any defective or nonconforming product, or part or parts of the product. Seller shall have the option to furnish either new or exchange replacement parts or assemblies.

Warranty service during the applicable warranty period will be performed without charge to Buyer within the contiguous 48 United States during Seller's normal business hours. After the warranty period, service will be performed at Seller's prevailing service rates. Subject to the availability of personnel, after-hours service is available upon request at an additional charge. For service outside the contiguous 48 United States, travel and per diem expenses, when required, shall be the responsibility of the Buyer, or End User, whichever is applicable.

The remedies set forth herein are conditioned upon Buyer promptly notifying Seller within the applicable warranty period of any defect or nonconformance and making the product available for correction.

The preceding paragraphs set forth Buyer's exclusive remedies and Seller's sole liability for claims based on failure of the products to meet any warranty, whether the claim is in contract,

warranty, tort (including negligence and strict liability) or otherwise, and however instituted, and, upon the expiration of the applicable warranty period, all such liability shall terminate. IN NO EVENT SHALL SELLER BE LIABLE TO BUYER FOR ANY SPECIAL INDIRECT, INCIDENTAL OR CONSEQUENTIAL DAMAGES OF ANY KIND ARISING OUT OF, OR AS A RESULT OF, THE SALE, DELIVERY, NON-DELIVERY, SERVICING, ASSEMBLING, USE OR LOSS OF USE OF THE PRODUCTS OR ANY PART THEREOF, OR FOR ANY CHARGES OR EXPENSES OF ANY NATURE INCURRED WITHOUT SELLER'S WRITTEN CONSENT DESPITE ANY NEGLIGENCE ON BEHALF OF THE SELLER. IN NO EVENT SHALL SELLER'S LIABILITIES UNDER ANY CLAIM MADE BY BUYER EXCEED THE PURCHASE PRICE OF THE PRODUCT IN RESPECT OF WHICH DAMAGES ARE CLAIMED. This agreement shall be construed in accordance with laws of the State of Illinois. In the event that any provision hereof shall violate any applicable statute, ordinance, or rule of law, such provision shall be ineffective to the extent of such violation without invalidating any other provision hereof.

Any controversy or claim arising out of or relating to the sale, delivery, non-delivery, servicing, assembling, use or loss of use of the products or any part thereof or for any charges or expenses in connection therewith shall be settled in Austin, Texas by arbitration in accordance with the Rules of the American Arbitration Association, and judgment upon the award rendered by the Arbitrator may be entered in either the Federal District Court for the Western District of Texas or the State District Court in Austin, Texas, all of the parties hereto consenting to personal jurisdiction of the venue of such court and hereby waive the right to demand a jury trial under any of these actions

6. APPENDIX A: HI-4450/FP2080/FP4080/FP5080 ERROR CODES

PROBE ERROR OUTPUT

If an error occurs, the probe will respond with one of the following strings. These strings begin with a colon and end with a carriage return.

E01 Communication error (e.g., overflow).

E02 Buffer full error. Too many characters contained between the Start Character/Carriage Return sequence.

E03 The received command is not valid.

E04 The received parameter is not valid.

E05 Hardware error (e.g., EEPROM failure).

E06 Parity error.

This page intentionally left blank.

7. APPENDIX B:

HI-4450/FP2080/FP4080/FP5080 OPERATING PROTOCOLS

The information in this appendix assumes that you have purchased the optional HI-4413G Fiber Optic/RS232 Interface, and are capable of communicating directly with the HI-4450/FP2080/FP4080/FP5080 probe via computer. No system readout is required when using this configuration.

COMMUNICATION PROTOCOL

Data Type:	RS-232 Serial
Data Mode:	Asynchronous
Word Length:	7 bit
Parity:	Odd
Stop Bits:	1
Data Rate:	9600 baud

INFORMATION TRANSFER PROTOCOL

The HI-4450/FP2080/FP4080/FP5080 operates as a Controller Mode device. This probe only responds to commands from another device; it transmits no data without receiving instructions to do so.

COMMAND STRUCTURE

A command to an HI-4450/FP2080/FP4080/FP5080 probe consists of

- 1) A command letter, followed by
- 2) Possible parameters
- 3) Terminated with a carriage return

When it completes the command, the probe responds with a string consisting of

- 1) S start character (":")
- 2) The command letter, followed by
- 3) Data, if required, and terminated with
- 4) A carriage return

If the command does not require the probe to return any data, the probe simply responds with the command letter and a carriage return. If an error occurs, the probe responds with an error code, as detailed in Appendix A.

COMMANDS

Command	Description
B	Read battery voltage.
Cx	Set baud rate. x = 1 sets rate to 2400 baud x = 2 sets rate to 9600 baud New baud rate does not take effect until the next power-up.
Dx	Read probe data. x = 1 enables short form output x = 2 enables long form output
Lx	Load table data. x = ASCII hex data
Rx	Set range. x = 1, 2, 3, 4 or N (next range)
Sx	Sleep timer. x = number of seconds to wait for a command before putting the probe into the sleep mode.
Tx	Read Temperature. x = C or F

NiCd Battery Fast Charger

Ux	Set unit type. x = 1, 2, 3, or N (next unit) 1 = V/m 2 = mW/cm ² 3 = [V/m] ²
Vtx	Verify table data. t = table (same table as for the Lx command, above). x = number of bytes to send in one string.
Z	Zero.
Null	Send the ASCII null character. This is a special command that can be used as the initial command to the probe after it is powered up. The probe responds with "N".

PROBE OUTPUT

Command	HI-4450/FP2080/FP4080/FP5080 Response
B	Bxx.xx, where xx.xx is the battery voltage.
D1	Dxx.xxuuu, the short form output. xx.xx is the reading. The position of the decimal point depends upon the range setting of the probe. uuu = units _V_ = V/m, mW2 = mW/cm ² , _V2 = [V/m] ² (underscore indicates a space character)
D2	Dxx.xxuuurrrobaaat, the long form output. xx.xx = the reading, as described for D1. uuu = units, as describe for D1. rrr = recorder out value (A 3-digit ASCII number from 0 to 255). o = over range indicator ("N" = ok, "O" = over range). b = battery status ("N" = safe operating level, "W" = warning level, "F" = fail level). aaa = axis enable ("E" = enabled). t = terminating carriage return.
Rx	Rx, where x is the range. x = "" returns the range currently in use x = 1, 2, 3, 4 enables the selected range x = N sets the probe to the next (higher) range.
TF	Txxx, where xxx is temperature in ° Fahrenheit.
TC	Txxx, where xxx is temperature in ° Centigrade.
Vtx	Vxx[xx...], where xx is table data in ASCII hex.

8. APPENDIX C: BATTERY CHARGER USER MANUAL

This page intentionally left blank.

Series 491198-36

NiCd Battery Fast Charger

User's Manual

Declaration of Conformity

ETS-Lindgren, L.P.
1301 Arrow Point Drive
Cedar Park, TX 78613
USA

Declares that the HOLADAY product described in this instruction manual is in compliance with: EN IEC 86/336/EEC, EN50082-1, EN55011



ETS-Lindgren, L.P.
(Formerly Holaday Industries, Inc.)



ETS-Lindgren L.P. reserves the right to make changes to any product described herein in order to improve function, design or for any other reason. Nothing contained herein shall constitute ETS-Lindgren L.P. assuming any liability whatsoever arising out of the application or use of any product or circuit described herein. ETS-Lindgren L.P. does not convey any license under its patent rights or the rights of others.

© Copyright 2004 by ETS-Lindgren L.P. All Rights Reserved.
No part of this document may be copied by any means
without written permission from ETS-Lindgren L.P.

EMAIL & INTERNET

support@ets-lindgren.com
<http://www.ets-lindgren.com>

USA

1301 Arrow Point Dr., Cedar Park TX 78613 USA
P.O. Box 80589, Austin, TX 78708-0589 USA
Tel 512.531.6400
Fax 512.531.6500

FINLAND

Mekaanikontie 1, 27510, Eura, Finland
Tel 358.2.838.3300
Fax 358.2.865.1233

JAPAN

4-2-6, Kohinata
Bunkyo-ku
Tokyo 112-0006 JAPAN
Phone + 81 3 3813 7100

Fax + 81 3 3813 8068

CHINA

1917-1918 Xue Zhixuan Building
No 16 Xue Qing Road
Haidian District

Beijing Postcode: 100083 CHINA

Phone + 86 10 82755304

Fax + 86 10 82755307

Table of Contents

1.0	General Safety Considerations	41
1.0	General Safety Considerations	41
2.0	Description.....	43
3.0	Unpacking and Acceptance.....	45
4.0	Specifications.....	47
5.0	Operating Instructions	51
6.0	Maintenance.....	55

Revision Record
Manual #600086
Series 491198-36 NiCd Battery Fast Charger

Revision	Description	Date
	Release	4/99
A	Changed Area Code	2/00
B	Updates	12/04

1.0 General Safety Considerations



Warning

This symbol alerts the user that important literature concerning the operation and maintenance of this unit has been included. Therefore, it should be read carefully in order to avoid any problems.

This is a Safety Class I product (provided with a protective earthing ground incorporated in the power cord). The mains plug shall only be inserted in a socket outlet provided with a protective earth contact. Any interruption of the protective conductor, inside or outside the instrument, is likely to make the instrument dangerous. Intentional interruption is prohibited. DO NOT defeat the earth-grounding protection by using an extension cable, power cable, or autotransformer without a protective ground conductor.



This instrument is to be used with a three-wire power cord set which meets or exceeds the requirements of EN60799. The power cord set used must be rated for a minimum of 250V/10A. When connected to an appropriate power line outlet, this cable grounds the instrument cabinet.



Warning--No operator serviceable parts exist inside the device. Refer servicing to qualified personnel. To prevent electrical shock, do not remove cover.



Warning--If this instrument is used in a manner not specified by ETS-Lindgren, the protection provided by the instrument may be impaired.



Warning--This battery charger incorporates parts, such as a switch and relay that potentially could produce sparks or arcs.



Warning--For indoor use only, do not expose to rain.

2.0 Description

The 491198-36 NiCd Battery Fast Charger is a dual power source battery charger. It charges 3.6 volt 1400 mAH NiCd batteries and is powered by 120-240 Vac line power or 12.5 Vdc. The 491198-36 uses a $-(dV)/(dT)$ (negative delta V) technique to determine when the battery is fully charged, typically one hour. With this technique, the charge state of the battery has no effect other than shortening the charge time.

Housed in a rugged enclosure, power enters the battery charger through a power entry module, which contains the fuses, or an optional cigarette lighter plug adapter. LEDs and the label on the front face of the unit provide operating status. The battery charger connects to the device being charged through a short cord terminated with a power jack.

An integrated circuit within the charger monitors the battery voltage and controls the charging functions according to the charge state of the battery.

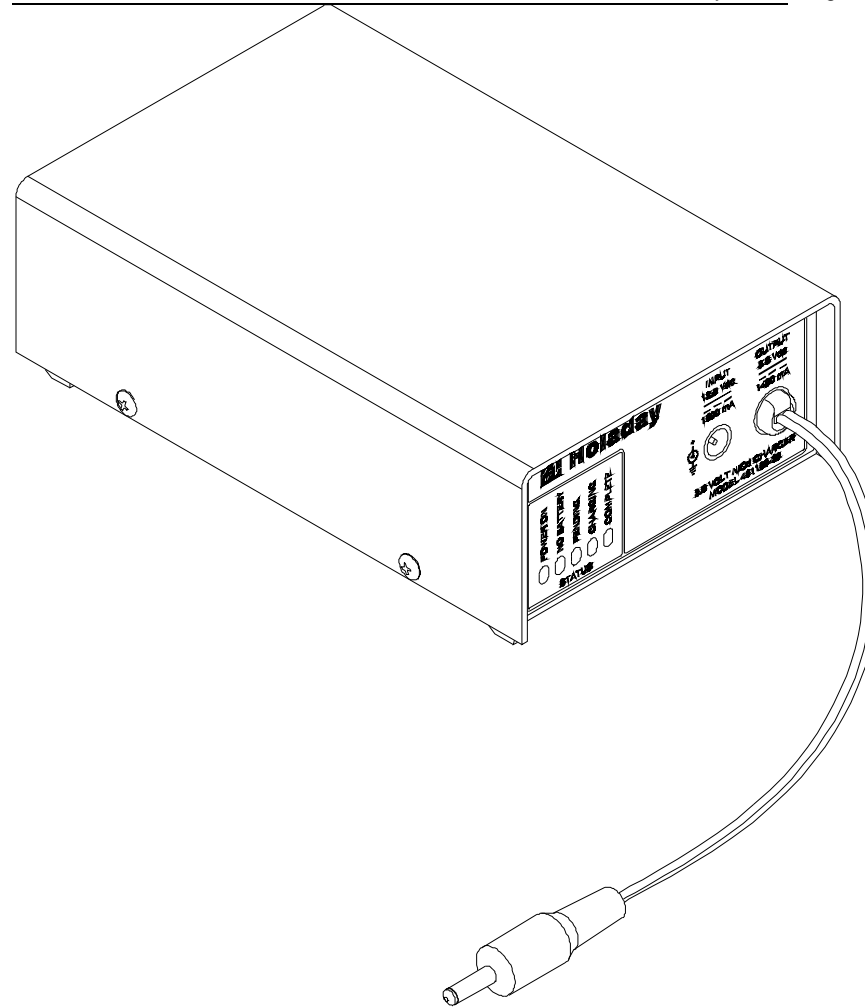

Figure 1: 3.6V Battery Charger

3.0 Unpacking and Acceptance

Introduction

This section contains information on unpacking and acceptance of the 491198-36 NiCd Battery Fast Charger.

Step 1. Upon delivery of your order, inspect the shipping container(s) for evidence of damage. Record any damage on the delivery receipt before signing. In case of concealed damage or loss, retain the packing materials for inspection by the carrier.

Step 2. Remove the product from its shipping container. Save boxes and any protective packing materials for future use.

Step 3. Check all materials against the packing list to verify that the equipment received matches that which was ordered. If you find any discrepancies, note them and call ETS-Lindgren Customer Service for further instructions.

Be sure that you are satisfied with the contents of your order and the condition of your equipment before using it.

4.0 Specifications

Power

Main:	IEC filtered AC power input module 110 - 240 Vac, 500 mA MAX., 50 - 100 Hz
Alternate:	Automobile cigarette lighter to 2mm power plug adapter cord., 12.5 Vdc, 100 mA
Fuses:	250 Volt, 1.0 Amp, Type T (5 mm x 20 mm)

Output

Open Circuit Voltage:	15 Vdc
Fast Charge Pending Current:	60 mA
Fast Charge Current:	1400 mA
Pulsed Trickle Charge Current:	50 mA
Output Voltage (During Fast Charge):	3 - 6 Vdc

NiCd Battery:

3.6 Volt 3 Cell NiCd Battery, 1400 mAH (Rapid charge cells, 1.2 volts/cell); ETS-Lindgren Part #491038

Environmental

Operating temperature	10 to 40° C
Humidity:	5% to 95% relative humidity, non-condensing

Power Cable

This charger is shipped with a three-wire power cable. When this cable is connected to an appropriate AC power source, it connects the chassis to earth ground. The type of power cable shipped with each battery charger depends on the country of destination.

Power Cable Set Information

ETS-Lindgren Part No.	Manufacturer, Part No. and Information
2217500	Volex #17500 Type SVT, Foil shielded, PVC Jacketed, 60°C Molded PVC Grounding Plug NEMA 5-15P UC-004 Molded PVC Receptacle IEC320/C13 UC-005 18 Ga. 3 Cond. 10A-125V
2217506C	Volex #17506 Type SVT, Foil shielded, PVC Jacketed, 60°C Molded PVC Grounding Plug NEMA 5-15P UC-004 Molded PVC Right-Angle Receptacle IEC320/C13 UC-006 18 Ga. 3 Cond. 10A-125V Countries: Canada, Japan, Puerto Rico, Taiwan, Venezuela, Hong Kong, United States
221100	Kobiconn #173-7001 Type H05VV-F, PVC Jacketed, 70°C Molded PVC Right-Angle Grounding Plug CEE 7/7 UC-814 Molded PVC Receptacle IEC320/C13 UC-051 1.0mm ² 3 Cond. 10A-250V Countries: Argentina, Austria, Brazil, Finland, France, Germany, Israel, Italy, Holland, Korea, Netherlands, Norway, Sweden, Turkey
222600	QualTek #370001-E01 Type H05VV-F, PVC Jacketed, 70°C, Harmonized Molded PVC Grounding Plug BS 1363, Fused UC-851 Molded PVC Receptacle IEC320/C13 UC-852 1.0mm ² 3 Cond. 10A-250V Countries: England, Ireland, Malaysia, Scotland, Singapore, South Africa, Wales
221600	Leeds Electronic Components #FFBS-1310 Type SAA, Ordinary Duty, PVC Jacketed, 75°C Molded Grounding Plug AS3112 UC-822 Molded PVC Receptacle IEC320/C13 UC-051 1.0mm ² 3 Cond. 10A-250V Countries: Australia, China

NiCd Battery Fast Charger

ETS-Lindgren Part No.	Manufacturer, Part No. and Information
221500	Volex #2102H-C3-10
	Type H05VV-F, PVC Jacketed, 70°C
	Molded PVC Grounding Plug SEV 1011 UC-841
	Molded PVC Receptacle IEC320/C13 UC-051
	1.0mm ² 3 Cond. 10A-250V
	Country: Switzerland

This page intentionally left blank.

5.0 Operating Instructions

The 491198-36 battery charger is intended to charge the 3.6 volt NiCd batteries, either in the lab or in the field.

Input Power Requirements

The 491198-36 charger may be powered by standard line voltage (110 - 240 Vac, 50 - 60 Hz) or by an optional automobile cigarette lighter plug (12.5 Vdc), see specifications. The AC power entry module contains a fuse.

Fuse Replacement

If a fuse has blown, it must be replaced with the same type and value or an unsafe condition may result. Refer to Figure 2 for fuse replacement.

The fuse is contained in the fuse drawer in the power input module. To access the fuse, use a screwdriver to pry the drawer open and remove it from the module. The drawer holds two fuses; the fuse towards the outside of the drawer is a spare.

After the fuse has been replaced, slide the fuse drawer back into the module. Make sure that it snaps securely into its locked position.

CAUTION

NEVER attempt to change the fuse with the battery charger plugged in.

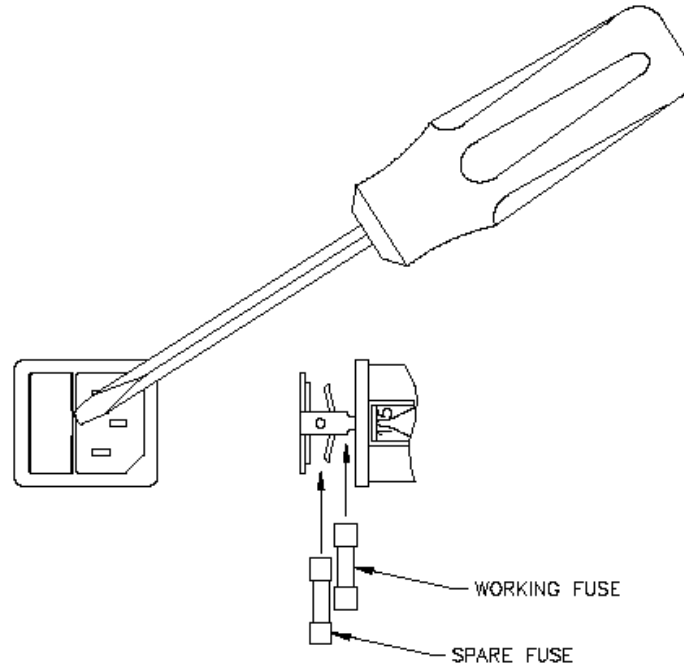

Figure 2: Fuse Replacement

Charging a Battery

After connecting the battery charger to a proper power source, the battery charger simply plugs into the charger jack on the HI-6005. The HI-6005 must be turned off or the battery will not charge.

CAUTION

NEVER attempt to recharge a non-rechargeable battery.

Charging Indicators

There are five LEDs located on the front of the charger that provide operating information to the user.

The “POWER ON” LED (green) will remain illuminated as long as the charger is plugged into the AC power source.

If the charger does not detect a battery, the “NO BATTERY” LED (amber) light will illuminate.

When the charger does detect the unit’s battery, the “PENDING” LED (amber) light illuminates while the charger qualifies the battery for fast charge. If the voltage is below the safe fast charge level, the battery is charged in the pulse trickle mode.

When the voltage is at a safe level the charger will switch to the fast charge mode and the “CHARGING” LED (amber) light illuminates.

When charging is complete, the charger switches back to the pulse trickle mode and the “COMPLETE” LED (green) light will illuminate. The device can be left on the charger in this maintenance mode indefinitely.

This page intentionally left blank.

6.0 Maintenance

Electronic instruments are delicate. Operate the battery charger with care.

User serviceable parts do not exist inside the battery charger. Warranty may be void if the battery charger housing is opened.

If the battery charger fails to operate, check for a blown fuse inside the power entry module (refer to figure 2).

CAUTION

NEVER attempt to change the fuse with the battery charger plugged in.

If a fuse is blown it must be replaced. Be sure to use only 250 Volt, 1.0 Amp, Type T (5 mm x 20 mm).

If the battery charger still fails to operate, or if you have any questions concerning charging your products, contact ETS-Lindgren Customer Service.