

*Model 94456*

# **Current Probe**

## MANUAL



94456-5



EMC Test Systems, L.P. reserves the right to make changes to any product described herein in order to improve function, design or for any other reason. Nothing contained herein shall constitute EMC Test Systems, L.P. assuming any liability whatsoever arising out of the application or use of any product or circuit described herein. EMC Test Systems, L.P. does not convey any license under its patent rights or the rights of others.

© Copyright 2002 by EMC Test Systems, L.P. All Rights Reserved.  
No part of this document may be copied by any means  
without written permission from EMC Test Systems, L.P.

**E-MAIL & INTERNET**

Support@ets-lindgren.com  
<http://www.ets-lindgren.com>

**USA**

1301 Arrow Point Dr., Cedar Park, TX 78613  
P.O. Box 80589, Austin, TX 78708-0589  
Tel 512.531.6400 Fax 512.531.6500

**FINLAND**

Euroshield OY  
Mekannikontie 1  
27510, Eura, Finland  
Tel 358.2.838.3300  
Fax 358.2.865.1233

**SINGAPORE**

Lindgren RF Enclosures Asia-Pacific  
87 Beach Road  
#06-02 Chye Sing Building  
Singapore 189695  
Tel 65.536.7078 Fax 65.536.7093

## Table of Contents

<b>INTRODUCTION.....</b>	<b>1</b>
<b>PRINCIPLES OF OPERATION.....</b>	<b>2</b>
CIRCUIT .....	2
SENSITIVITY .....	3
CORE SATURATION AND INTERMODULATION .....	3
TRANSFER IMPEDANCE.....	4
<b>INSTALLATION .....</b>	<b>5</b>
EQUIPMENT SETUP .....	5
INSTALLATION .....	6
<b>TYPICAL TEST CONFIGURATION.....</b>	<b>7</b>
<b>PRECAUTIONARY MEASURES .....</b>	<b>8</b>
<b>OPERATION .....</b>	<b>9</b>
SIGNAL MEASUREMENT .....	9
<i>Oscilloscope Use – In terms of RF Amperes .....</i>	<i>9</i>
<i>In Terms of dB Above One Microampere at Meter Input (CW Conducted</i>	
<i>Measurements) .....</i>	<i>9</i>
<i>In Terms of dB Above One Microampere per Megahertz at Meter Input (Broadband</i>	
<i>Interference Measurement).....</i>	<i>10</i>
<i>In Terms of Microampere in Test Sample Lead (CW Conducted Measurements)....</i>	<i>11</i>
<i>In Terms of Microampere per Megahertz in Test Sample Lead (Broadband</i>	
<i>Interference Measurement).....</i>	<i>12</i>
<b>SPECIFICATIONS.....</b>	<b>13</b>
<b>MAINTENANCE .....</b>	<b>15</b>
<b>WARRANTY STATEMENT .....</b>	<b>16</b>



# INTRODUCTION

---

The ETS-Lindgren EMCO brand Model 94456 RF Current Probe is a clamp-on RF current transformer designed for use with Electromagnetic Interference (EMI) Test Receivers/Spectrum Analyzers, or with any similar instrument having a 50 Ohm input impedance, to determine the intensity of RF current present in an electrical conductor or group of conductors.

The Current Probe provides a means of accurately measuring net (common mode) radio frequency current flowing on a wire or bundle of wires without requiring a direct connection to the conductor(s) of interest. The Model 94456 Current Probe is simply clamped around the test conductor which then becomes a one turn primary winding, with the current probe forming the core and secondary winding of an RF transformer. Measurements can be made on single and multi-conductor cables, grounding and bonding straps, outer conductors of shielding conduits and coaxial cables, etc.

# PRINCIPLES OF OPERATION

The RF Current Probe, Model 94456 is an inserted-primary type of radio frequency current transformer. When the probe is clamped over the conductor or cable in which current is to be measured, the conductor forms the primary winding. The clamp-on feature of this probe enables easy placement around any conductor or cable.

## CIRCUIT

The circuit is that of a radio frequency transformer as illustrated below:

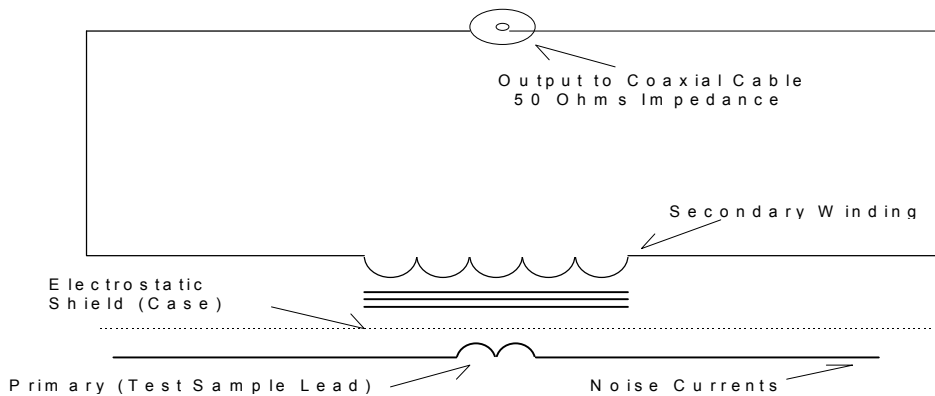

**Figure 1. Basic RF Transformer**

Since the current probe is intended for “clamp on” operation, the primary shown in Figure 1 is actually the electrical conductor in which interference currents are to be measured. This primary is considered as one turn since it is assumed that the noise currents flow through the conductor and return to the source via a “ground” conductor such as a frame, common ground plane, or earth. On some current probe models the secondary output terminals are resistively

loaded internally to provide substantially constant transfer impedance over a wide frequency range.

## SENSITIVITY

---

Probe sensitivity in microamperes is dependant upon the sensitivity in microvolts of the receiving equipment with which it is used. The following table shows the relationship of receiving sensitivity in microvolts to the overall sensitivity of the probe and receiver in microamperes. This data is based on the transfer impedance of each model.

Test Equipment Sensitivity in microvolts	94456-5 $Z_T = 0.006 \text{ W}$
5	830
2	332
1	166
0.1	16.6

**Table 1. Model 94456 Series Typical Sensitivity**

## CORE SATURATION AND INTERMODULATION

---

The magnetizing effects of a primary conductor carrying large currents at power line frequencies can saturate the current probe core material. Core saturation produces non-linear transforming action and can result in (a) a decrease in the current probe RF output for a given RF current input, and (b) modulation of the RF output by the power line frequency.

The specified pulse duty cycle should not be exceeded or the current probe internal load resistor (if applicable) may

be subject to damage. The load resistor must also be protected from excessive line currents.

The influence of intermodulation on the current probe output as measured with the EMI test equipment is negligible for primary conductor power frequency currents under 300 Amperes. For primary power currents above 300 Amperes, measurements taken by the EMI test equipment generally will not be affected by intermodulation because of its “averaging” characteristics for the Quasi Peak and Peak functions, the readings will increase with current.

## TRANSFER IMPEDANCE

The RF current ( $I_P$ ) in microamps in the conductor under test is determined from the reading of the current probe output in microvolts ( $E_S$ ) divided by the current probe transfer impedance ( $Z_T$ ).

$$I_P = E_S / Z_T$$

Or, in dB

$$I_P(\text{dB}\mu\text{A}) = E_S(\text{dB}\mu\text{V}) - Z_T(\text{dB})$$

The typical transfer impedance of the current probe throughout the frequency range is determined by passing a known RF current ( $I_P$ ) through the primary test conductor and noting the voltage,  $E_S$ , developed across a 50 Ohm load. Then,

$$Z_T = E_S / I_P$$



# INSTALLATION

---

This section describes methods for setting up the current probe and associated measuring equipment. Operating procedures are contained in the Operation section.

## EQUIPMENT SETUP

---

In measuring the RF current in a single conductor, the probe jaws are placed around the conductor so that the conductor passes through the center opening and then the jaws are locked together. In the case of a two-conductor cable, the probe can be used to evaluate the common mode component of the noise current (the net effect of the currents leaving and returning) by placing the probe over both conductors at the same time, or the interference current in either conductor can be measured separately by placing the probe over each wire individually.

In a more complex case of multi-conductor cables, the probe will measure the net external effects of all the currents in the conductors that pass through the center of the probe.

When placed over shielding conduit, coaxial cable, or ignition shielding, the probe measures the current flowing on the external surface of the shield. The probe can thus be used to evaluate the shielding effectiveness.

*NOTE: Standing waves can exist on the test conductor under test at or near its resonant frequency. Under these*

*conditions, several measurements taken along the line will provide a complete picture of the RF current distribution and amplitude.*

## INSTALLATION

---

The window (aperture) of the probe will accommodate cables up to a maximum outside diameter of 4.0 inches.

After placing the probe around the conductor(s) to be measured, the probe jaws should be carefully locked. If this is not done, inadequate shielding or incorrect air gap will result and the measurement will not be accurate.

The connecting cable used between the current probe and the EMI test equipment must have a 50 Ohm characteristic impedance and matching cable connectors. The current probe is calibrated for use only with a 50 Ohm load. Therefore, the EMI test equipment must have a 50 Ohm input impedance. Precautions regarding minimum bending radius should be observed when installing and using the cable. For long cables and at high frequencies, cable loss may also be a factor. Care should be taken to use low loss cables and to perform cable loss corrections if necessary.

The probe rejection of any external pickup from conductors not passing through the window is better than 60 dB. The presence of very strong magnetic fields will likely have an effect on probe sensitivity. Care must be taken not to place the unit close to permanent magnets or the magnetic field structures of motors or generators.

For greatest accuracy, the conductor under measurement should be centered in the window of the current probe.

## TYPICAL TEST CONFIGURATION

---

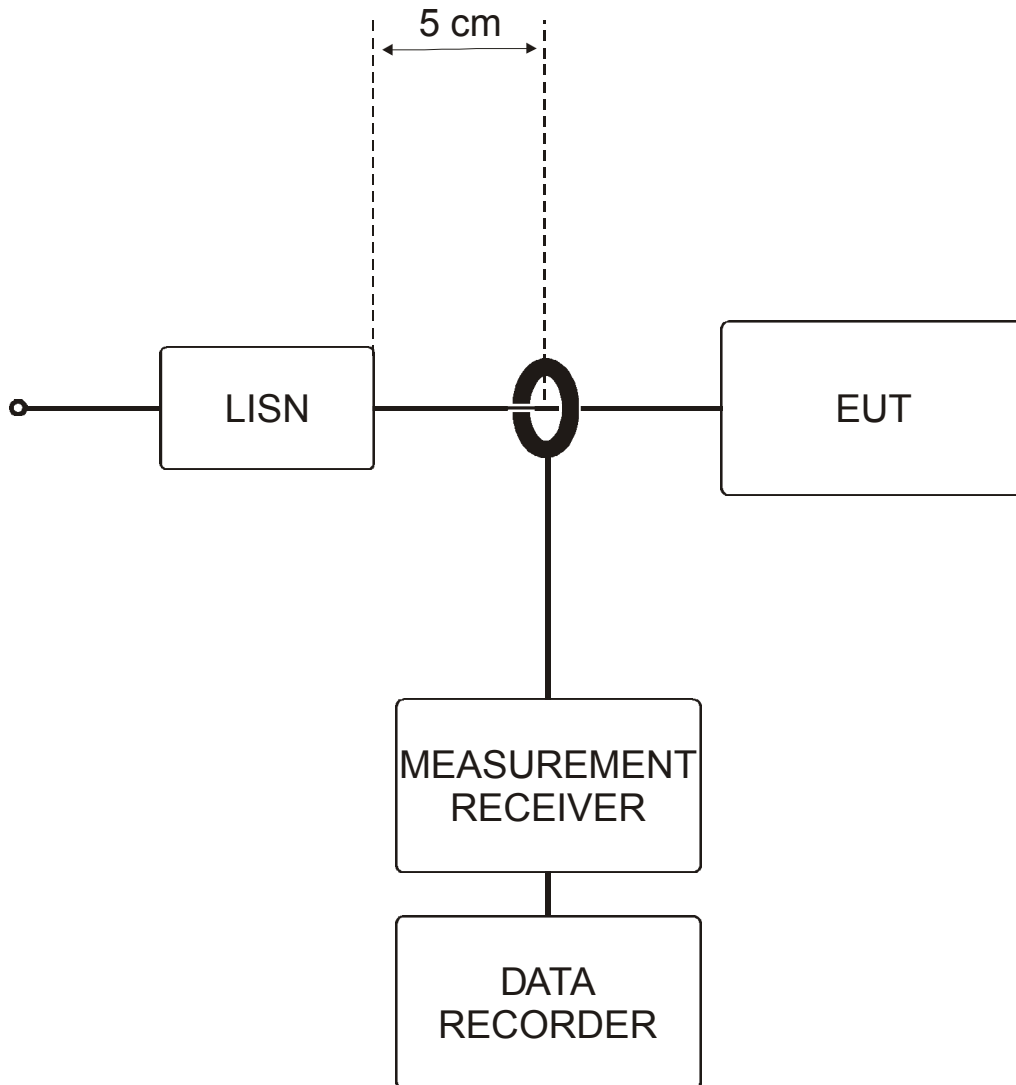

# PRECAUTIONARY MEASURES

---



When measuring uninsulated conductors use extreme care when installing the current probe and taking measurements. If possible, de-energize the test sample during assembly and disassembly of the setup. Also, arrange to center the test conductor in the current probe window for additional voltage breakdown protection.

Do not permit the uninsulated current probe connector and cable connectors to come in contact with the ground plane or other nearby conductors. This will prevent possible measurement error due to ground loops, and will avoid danger from high voltages.

Ensure that the 50 Ohm load is capable of safely dissipating the incurred power. Should the load become disconnected, the developed voltage will be come much greater and may be very dangerous.

# OPERATION

---

The RF current probe is a broadband RF transformer for use with EMI test equipment. Radio frequency currents can be measured in cables without physically disturbing the circuit.

## SIGNAL MEASUREMENT

---

### Oscilloscope Use – In terms of RF Amperes

1. Standardize the gain of the oscilloscope to read correctly the voltage ( $E_S$ ) applied to its input terminals.
2. Divide  $E_S$  in volts by the average current probe transfer impedance  $Z_T$  in Ohms. The result is the value of the RF signal in terms of Amperes in the test conductor.

#### Example:

Assume an oscilloscope peak voltage measurement of 5 Volts and the average  $Z_T$  to be 1.06 Ohms. Then:  $5/1.06 = 4.71$  Amperes in the test conductor. The example is valid providing that the oscilloscope rise time ( $T = 0.3/BW$ ) is shorter than RF signal pulse duration. This also applies to the current probe which has a rise time of about 3 nanoseconds based on a 100 megahertz bandwidth.

### In Terms of dB Above One Microampere at Meter Input (CW Conducted Measurements)

1. Adjust the EMI test equipment for standard gain and make a measurement of the CW signal (voltage output from the current probe) in terms of dB above one

- microvolt. Use procedures outlined in the EMI test equipment instruction manual.
2. Subtract the transfer impedance of the current probe in dB at the test frequency from the dB measurement of Step (1). The result is the value of the conducted CW signal in terms of dB above one microamp at meter input.<sup>1</sup>

Example:

Frequency is 10.0 kHz; Step (1) measurement is 52 dB above one microvolt. For example, suppose the transfer impedance of the current probe used in the example was 8.0 dB below one Ohm at 10.0 kHz. Then, as outlined in Step (2);  $52 \text{ dB} + 8.0 \text{ dB} = 60 \text{ dB}$  above one microampere at meter input.

**In Terms of dB Above One Microampere per Megahertz at Meter Input (Broadband Interference Measurement)**

1. Adjust the EMI test equipment for standard gain and make a Peak measurement of the broadband interference (voltage output from the current probe) in terms of dB above one microvolt-per-megahertz. Use procedures outlined in the EMI test equipment instruction manual.
2. Subtract the transfer impedance of the current probe in dB at the test frequency from the dB measurement of Step (1). The result is the value of the broadband

---

<sup>1</sup> The term “at meter input” as used in the MIL-I-26600 and MIL-I-6181D specifications refers to the current in the test sample lead.

interference in terms of dB above one microamp-per-megahertz at meter input.\*

Example:

Frequency is 100 kHz; Step (1) measurement is 41 dB above one microvolt-per-megahertz. For example, suppose the transfer impedance of the current probe was 8.0 dB below one Ohm at 100 kHz. Then, as outlined in Step (2):  
 $41 \text{ dB} + 8.0 \text{ dB} = 49 \text{ dB}$  above one microamp-per-megahertz at meter input.<sup>2</sup>

This result is beyond the limit of 46.2 dB above one microamp-per-megahertz .

**In Terms of Microampere in Test Sample Lead (CW Conducted Measurements)**

1. Adjust the EMI test equipment for standard gain and make a measurement of the CW signal (voltage output from current probe) in terms of microvolts at meter input. Use procedures outlined in the EMI test equipment instruction manual.
2. Divide the microvolt measurement of Step (1) by the transfer impedance in Ohms at the test frequency. The result is the value of conducted CW signal in terms of microamperes in the test sample lead.

Example:

Frequency is 3.0 kHz; Step (1) Measurement is 150 microvolts. For example, suppose the transfer impedance of

---

<sup>2</sup> The term “at meter input” as used in the MIL-I-26600 and MIL-I-6181D specifications refers to the current in the test sample lead.

the current probe was 0.34 Ohms. Then, as outlined in Step (2),  $150/0.34 = 441.1$  microamperes in test sample lead.

**In Terms of Microampere per Megahertz in Test Sample Lead (Broadband Interference Measurement)**

1. Adjust the EMI test equipment for standard gain and make a measurement of the broadband interference (voltage output from current probe), in terms of microvolts-per-megahertz at meter input. Use procedures outlined in the EMI test equipment instruction manual.
2. Divide the microvolt-per-megahertz measurement of Step (1) by the transfer impedance in Ohms at the test frequency. The result is the value of conducted broadband interference in terms of microamps-per-megahertz in test sample lead.

Example:

Frequency is 10.0 kHz; Step (1) measurement is 8,000 microvolts-per-megahertz. For example, suppose the transfer impedance of the current probe was 0.39 Ohms. Then, as outlined in Step (2),  $8000/0.39 = 20,513$  microamps-per-megahertz in test sample lead.



# SPECIFICATIONS

## PHYSICAL

Window Diameter	10.16 cm 4.0 in
Outside Diameter	17.46 cm 6.87 in
Width	5.71 cm 2.25 in
Weight	2.83 kg 6.25 lbs
Output Connector	Type N
Input Impedance	50 Ω

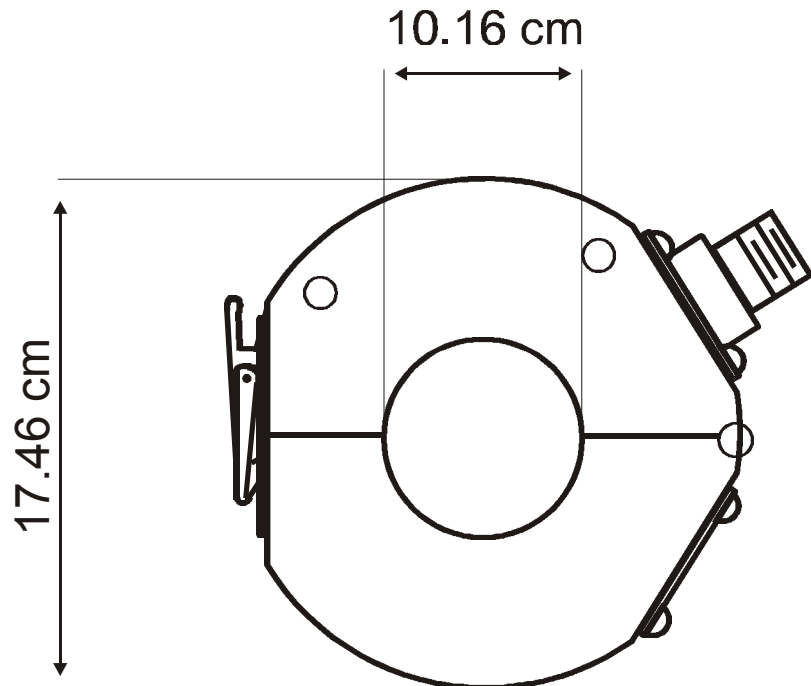

**SERIES SPECIFIC ELECTRICAL SPECIFICATIONS**

Electrical Specifications	91197-1
Frequency Range	10 kHz to 100 MHz
Transfer Impedance (Nominal)	0.006 Ohms
RF Current Range (RF CW)	0 to 40 Amps
RF Current Range (Pulse)	Pulse signals with peak currents to 4000 Amps can be measured if the pulse duty cycle does not exceed: (500 Amps I <sub>p</sub> ) 0.0065 Duty (1000 Amps I <sub>p</sub> ) 0.0016 Duty (2000 Amps I <sub>p</sub> ) 0.0004 Duty (3000 Amps I <sub>p</sub> ) 0.00018 Duty (4000 Amps I <sub>p</sub> ) 0.0001 Duty
Maximum Power Current	350 Amps at DC 250 Amps at 60 Hz 40 Amps at 400 Hz
Maximum Power Voltage	No limitation, subject to adequate conductor insulation.
Sensitivity Under Rated Load	6 millivolts across a 50 Ohm load for a 1 ampere RF signal in the primary

# MAINTENANCE

---

To ensure reliable and repeatable long term performance annual recalibration of your current probe by ETS-Lindgren's experienced technicians is recommended. Our staff can recalibrate almost any type or brand of current probe. Please call to receive a Service Order Number prior to sending a current probe to us for calibration.

For more information about our calibration services or to place an order for current probe calibration visit our calibration website at <http://www.antennacalibration.com/>.

# WARRANTY STATEMENT

---

**EMC Test Systems, L.P.**, hereinafter referred to as the Seller, warrants that standard EMCO products are free from defect in materials and workmanship for a period of two (2) years from date of shipment. Standard EMCO Products include the following:

- ❖ Antennas, Loops, Horns
- ❖ GTEM cells, TEM cells, Helmholtz Coils
- ❖ LISNs, PLISNs, Rejection cavities & Networks
- ❖ Towers, Turntables, Tripods & Controllers
- ❖ Field Probes, Current Probes, Injection Probes

If the Buyer notifies the Seller of a defect within the warranty period, the Seller will, at the Seller's option, either repair and/or replace those products that prove to be defective.

There will be no charge for warranty services performed at the location the Seller designates. The Buyer must, however, prepay inbound shipping costs and any duties or taxes. The Seller will pay outbound shipping cost for a carrier of the Seller's choice, exclusive of any duties or taxes. If the Seller determines that warranty service can only be performed at the Buyer's location, the Buyer will not be charged for the Seller's travel related costs.

This warranty does not apply to:

- ❖ Normal wear and tear of materials
- ❖ Consumable items such as fuses, batteries, etc.
- ❖ Products that have been improperly installed, maintained or used
- ❖ Products which have been operated outside the specifications
- ❖ Products which have been modified without authorization
- ❖ Calibration of products, unless necessitated by defects

**THIS WARRANTY IS EXCLUSIVE. NO OTHER WARRANTY, WRITTEN OR ORAL, IS EXPRESSED OR IMPLIED, INCLUDING BUT NOT LIMITED TO, THE IMPLIED WARRANTIES OF MERCHANTABILITY AND FITNESS FOR A PARTICULAR PURPOSE. THE REMEDIES PROVIDED BY THIS WARRANTY ARE THE BUYER'S SOLE AND EXCLUSIVE REMEDIES. IN NO EVENT IS THE SELLER LIABLE FOR ANY DAMAGES WHATSOEVER, INCLUDING BUT NOT LIMITED TO, DIRECT, INDIRECT, SPECIAL, INCIDENTAL, OR CONSEQUENTIAL DAMAGES, WHETHER BASED ON CONTRACT, TORT, OR ANY OTHER LEGAL THEORY.**

*Note: Please contact the Seller's sales department for a Return Materials Authorization (RMA) number before shipping equipment to us.*