

*Model HI-3702*

# Clamp-On Induced Current Meter

User Manual



 **ETS-LINDGREN**<sup>TM</sup>  
HOLADAY EMF MEASUREMENT

ETS-Lindgren L.P. reserves the right to make changes to any product described herein in order to improve function, design, or for any other reason. Nothing contained herein shall constitute ETS-Lindgren L.P. assuming any liability whatsoever arising out of the application or use of any product or circuit described herein. ETS-Lindgren L.P. does not convey any license under its patent rights or the rights of others.

**© Copyright 1995–2009 by ETS-Lindgren L.P. All Rights Reserved. No part of this document may be copied by any means without written permission from ETS-Lindgren L.P.**

Trademarks used in this document: The *ETS-Lindgren* logo is a trademark of ETS-Lindgren L.P.

**Revision Record | HI-3702 MANUAL | Part #H-600070, Rev. G**

<b>Revision</b>	<b>Description</b>	<b>Date</b>
	Initial Release	November, 1995
A	Updates	May, 1996
B	Update battery charger	June, 1997
C	Add CE label	June, 1997
D	Add <i>Appendix A</i>	January, 1998
E	Update battery charger specifications	August, 1999
F	Update contact information; reformat	February, 2006
G	Update frequency range; rebrand	February, 2009

# Table of Contents

<b>Notes, Cautions, and Warnings</b> .....	<b>v</b>
<b>General Safety Considerations</b> .....	<b>v</b>
<b>1.0 Introduction</b> .....	<b>7</b>
Standard Configuration.....	8
Optional Items.....	8
ETS-Lindgren Product Information Bulletin .....	8
<b>2.0 Maintenance</b> .....	<b>9</b>
Battery Maintenance.....	10
Annual Calibration .....	10
Maintenance of Fiber Optics.....	10
Replacement and Optional Parts.....	11
Service Procedures .....	12
<b>3.0 Ranges and Specifications</b> .....	<b>13</b>
Ranges .....	13
Specifications.....	13
HI-3702 Typical Frequency Response .....	15
<b>4.0 Operation</b> .....	<b>17</b>
Computer Controlled Data Logging .....	20
Battery Charging.....	20
Error Codes .....	21
<b>5.0 Functional Theory of Operation</b> .....	<b>23</b>
<b>Appendix A: Warranty</b> .....	<b>25</b>
<b>Appendix B: Series H-491198-36 Battery Charger</b> .....	<b>27</b>
Safety Precautions.....	27
Introduction.....	27
Charging a Battery.....	28
Charging Indicators.....	28
Specifications.....	29
Maintenance Recommendations .....	30
Replacing the Fuse.....	30

<b>Appendix C: EC Declaration of Conformity .....</b>	<b>33</b>
HI-3702 Clamp-On Induced Current Meter.....	33
Series H-491198-36 Battery Charger .....	34

## Notes, Cautions, and Warnings

---

	<p><b>Note:</b> Denotes helpful information intended to provide tips for better use of the product.</p>
<p><b>CAUTION</b></p>	<p><b>Caution:</b> Denotes a hazard. Failure to follow instructions could result in minor personal injury and/or property damage. Included text gives proper procedures.</p>
<p><b>WARNING</b></p>	<p><b>Warning:</b> Denotes a hazard. Failure to follow instructions could result in SEVERE personal injury and/or property damage. Included text gives proper procedures.</p>







See the ETS-Lindgren *Product Information Bulletin* for safety, regulatory, and other product marking information.

## General Safety Considerations

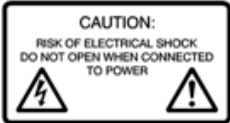
---

	<p><b>Warning:</b> This is a Safety Class I product (provided with a protective earthing ground incorporated in the power cord). The mains plug shall only be inserted in a socket outlet provided with a protective earth contact. Any interruption of the protective conductor, inside or outside the instrument, is likely to make the instrument dangerous. Intentional interruption is prohibited. DO NOT defeat the earth grounding protection by using an extension cable, power cable, or autotransformer without a protective ground conductor.</p>
---	--

	<p><b>Caution:</b> Uninsulated voltage within the unit may have sufficient magnitude to cause electric shock. Therefore, it is dangerous to make any kind of contact with any parts inside this unit.</p>
	<p><b>Caution:</b> This instrument is shipped with a three-wire power cable, in accordance with international safety standards. When connected to an appropriate power line outlet, this cable grounds the instrument cabinet.</p>
	<p><b>Warning:</b> No operator serviceable parts exist inside. Refer servicing to qualified personnel. To prevent electrical shock, do not remove covers.</p>
	<p><b>Warning:</b> The battery charger incorporates parts, such as a switch and relay that potentially could produce sparks or arcs.</p> <p><b>Warning:</b> For indoor use only, do not expose to rain.</p>



See the ETS-Lindgren *Product Information Bulletin* for safety, regulatory, and other product marking information.

## 1.0 Introduction

---

The **ETS-Lindgren HI-3702 Clamp-on Induced Current Meter** measures the induced body current of individuals working in environments where radio frequency (RF) electromagnetic fields are present. The HI-3702 is designed to meet the requirements of *IEEE C95.1-1991 Standard for Safety Levels with Respect to Human Exposure to Radio Frequency Electromagnetic Fields, 3 kHz to 300 GHz*.



Shown:  
*HI-3702 Clamp-On Current Sensor*  
*HI-4416 Digital Readout/Control Unit*

IEEE C95.1-1991 defines the acceptable levels of RF-induced body current for the frequency range of 3 kHz to 100 MHz. The acceptable levels range from 3 mA for uncontrolled exposures at 3 kHz, to 200 mA for controlled exposures between 100 kHz and 100 MHz.

The accuracy of the HI-3702 provides a means for determining compliance. The unit is completely portable and self-contained, and is simple to set up and easy to operate. The rugged design can be used for measurements in environments such as:

- Induction heating facilities
- Industrial welding applications
- Broadcast transmitting and antenna locations

## **Standard Configuration**

---

- HI-3702 Clamp-On Current Sensor with cushioned case
- HI-4416 Digital Readout/Control Unit with fiber optic cable
- Series H-491198-36 Battery Charger
- Carrying Case

## **Optional Items**

---

- Belt-Pac Readout/Control Unit Case
- HI-4413P Fiber Optic Modem

## **ETS-Lindgren Product Information Bulletin**

---

See the ETS-Lindgren *Product Information Bulletin* included with your shipment for the following:

- Warranty information
- Safety, regulatory, and other product marking information
- Steps to receive your shipment
- Steps to return a component for service
- ETS-Lindgren calibration service
- ETS-Lindgren contact information



## 2.0 Maintenance

---

### CAUTION

Before performing any maintenance, follow the safety information in the ETS-Lindgren *Product Information Bulletin* included with your shipment.



Maintenance of the HI-3702 is limited to external components such as cables or connectors.

Do not open the HI-3702 housing. Warranty may be void if the housing is opened.

If you have any questions concerning maintenance, contact ETS-Lindgren Customer Service.

Take care to keep dirt and moisture from getting inside the housing of the HI-3702 Clamp-on Induced Current Meter and on the coplanar surfaces of the ferrite core that are exposed when the clamp-on sensor is open. The cushioned case provides only minimal protection to the clamp-on sensor in keeping dirt or other particulate matter from entering the gap on the inner side of the housing.

Do not use high-pressure sprays, and under no circumstance should the unit be immersed in water or other liquid; the HI-3702 is not waterproof. Such actions void the warranty.

## Battery Maintenance

---



Under normal operating conditions, recharging the battery is the only HI-3702 maintenance performed by the user.

Maintaining the HI-3702 requires that the nickel-cadmium (NiCd) battery be properly charged and the battery condition monitored. The normal operational life of the battery (approximately 1000 charge/discharge cycles) is such that by the time the battery needs replacement; the HI-3702 will need recalibration; these tasks are performed by ETS-Lindgren. For information on calibration services, see *Annual Calibration* on page 10.

For the steps to charge the battery, see page 20.

In case of damage to the battery that causes premature failure, the HI-3702 must be sent to ETS-Lindgren for battery replacement; replacement in the field is not possible. See *Service Procedures* on page 11 for information on returning the HI-3702 to ETS-Lindgren for service.

## Annual Calibration

---

See the *Product Information Bulletin* included with your shipment for information on ETS-Lindgren calibration services.

## Maintenance of Fiber Optics

---

Fiber optic connectors and cables can be damaged from airborne particles, humidity and moisture, oils from the human body, and debris from the connectors they plug into. Always handle connectors and cables with care, using the following guidelines.



**Before performing any maintenance, disconnect the fiber optic cables from the unit and turn off power.**

**When disconnecting fiber optic cables, apply the included dust caps to the ends to maintain their integrity.**

**Before connecting fiber optic cables, clean the connector tips and in-line connectors.**

**Before attaching in-line connectors, clean them with moisture-free compressed air.**

**Failure to perform these tasks may result in damage to the fiber optic connectors or cables.**

## **Replacement and Optional Parts**

---

Following are the part numbers for ordering replacement or optional parts for the HI-3702.

<b>Part Description</b>	<b>Part Number</b>
HI-3702 Cushioned Case	H-51560044
HI-3702 Fitted Carrying Case	H-491132
HI-4416 Digital Readout/Control Unit	HI-4416
Fiber Optic Cable, 2-meter	H-491106-02
Series H-491198-36 Battery Charger	H-491198-36
Belt-Pac Readout/Control Unit Case	H-51560045
HI-4413P Fiber Optic Modem	HI-4413P
12V Auto Lighter Power Cord	H-22270-1534D

## **Service Procedures**

---

For the steps to return a system or system component to ETS-Lindgren for service, see the *Product Information Bulletin* included with your shipment.

### 3.0 Ranges and Specifications

---

#### Ranges

---

<b>Autorange:</b>	1.00 mA–1.000 A
<b>Range 1:</b>	1.00 mA–10.0 mA
<b>Range 2:</b>	3.1 mA–31.6 mA
<b>Range 3:</b>	10.0 mA–100.0 mA
<b>Range 4:</b>	0.031 A–0.316 A
<b>Range 5:</b>	0.100 A–1.000 A

#### Specifications

---

<b>Typical Frequency Response:</b>	9 kHz–70 MHz $\pm$ 2.0 dB
<b>Linearity:</b>	$\pm$ 0.5 dB At lower levels, the linearity for Range 1 deviates within $\pm$ 0.5 dB due to noise. The remaining ranges follow the ideal curve as shown for Range 2 in <i>Typical Frequency Response</i> on page 15.
<b>Fiber Optic Connectors:</b>	Standard FSMA
<b>Fiber Optic Cable:</b>	200 micron, Graded Index, Multimode, Max Length 1 Km
<b>Readout:</b>	HI-4416 Digital Readout/Control Unit

<b>Physical Specifications</b>	
<b>HI-3702 Inner Diameter:</b>	105.4 mm (4.15 in)
<b>HI-3702 Outer Diameter:</b>	171.4 mm (6.75 in)
<b>HI-3702 Height:</b>	72.6 mm (2.86 in)
<b>HI-3702 Weight:</b>	1.7 kg ( 3 lb 13 oz)
<b>HI-4416 Digital Readout/Control Unit:</b>	0.42 kg (14.8 oz)
<b>Cushioned Case:</b>	0.085 kg (3.0 oz)
<b>Fiber Optic Cable:</b>	0.071 kg (2.5 oz)
<b>Battery / Battery Charger</b>	
<b>Battery:</b>	3.6 VDC, 1400 mAH rechargeable nickel-cadmium (NiCd)
<b>Battery Charger:</b>	115/230 VAC, approximately one hour
<b>Battery Life:</b>	Approximately 5 hours of continuous operation per full charge
<b>Environmental</b>	
<b>Humidity:</b>	5% to 95% relative humidity, non-condensing
<b>Operating Temperature:</b>	10°C–40°C (50°F–104° F)

## HI-3702 Typical Frequency Response

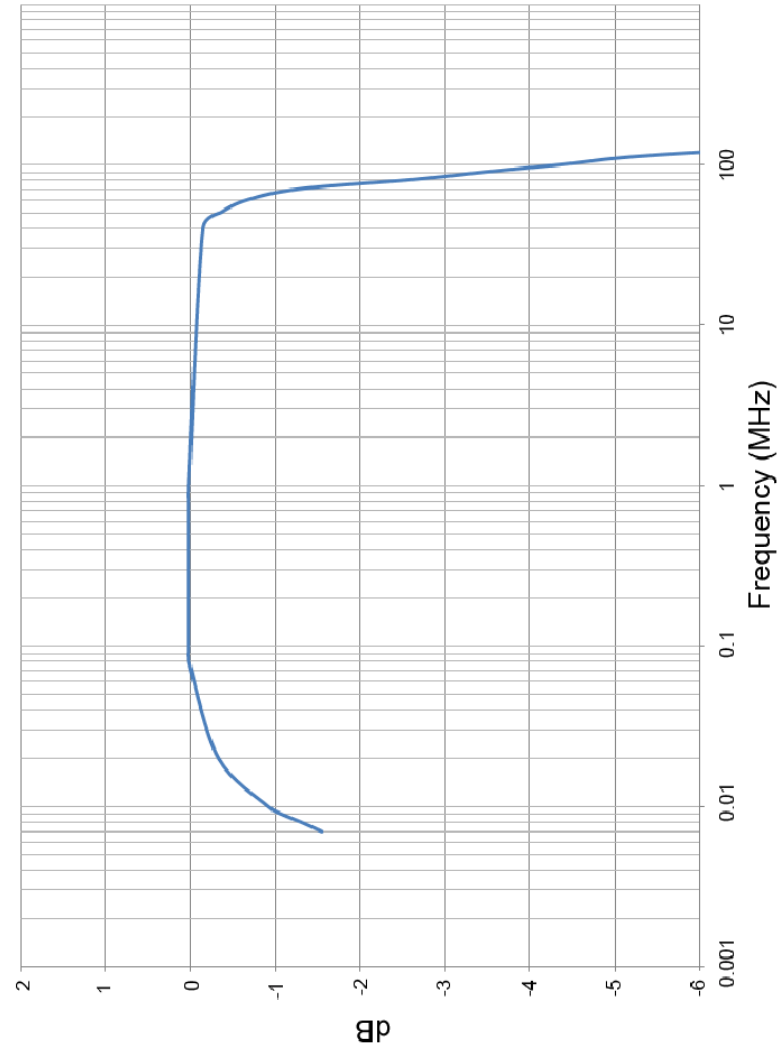

This page intentionally left blank.



## 4.0 Operation

---

### CAUTION

Before connecting any components, follow the safety information in the ETS-Lindgren *Product Information Bulletin* included with your shipment.

If you use this equipment in a manner not specified by ETS-Lindgren, the protection provided by the equipment may be impaired.

Do not position the equipment so that it is difficult to connect cables to or disconnect cables from the back of the unit.

#### 1. Charge the battery.

Before taking any measurements, charge the battery to maximum capacity. For the steps to charge the battery, see page 20.

The nickel-cadmium (NiCd) battery installed in the HI-3702 Clamp-on Induced Current Meter was charged prior to shipment; however, NiCd batteries can self-discharge to nearly zero capacity after two months.

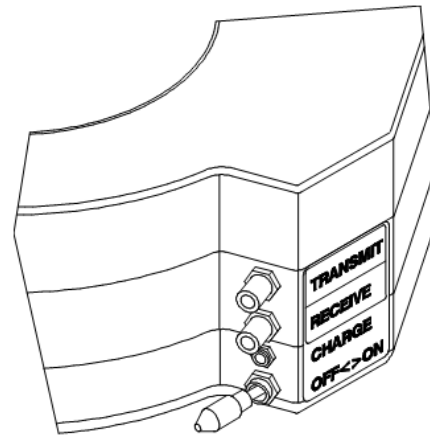

The battery charger requires approximately one hour to charge the battery to maximum capacity. Under normal operation, a fully-charged battery should provide five hours of operation. If the battery fails to hold a charge or if a significant degradation in operational time occurs, you may need to replace the battery.

**2. Connect the fiber optic cables.**

Connect the fiber optic cable to the HI-3702 and to the HI-4416 Digital Readout/Control Unit. Follow the color coding on the fiber optic cable, the HI-3702, and the HI-4416.

**3. Power on the HI-3702.**

Turn on the HI-3702. The HI-3702 is equipped with a locking lever on/off switch. Pull the switch lever out before toggling it to the appropriate position.

**4. Power on the HI-4416.**

Turn on the HI-4416. See the HI-4416 manual for more complete operating information.

**5. Select the range.**

Use the HI-4416 to select the range that is appropriate for the expected current levels to be measured. To select auto range, scroll through the ranges until **Range A** appears on the screen.

When auto range is enabled, the probe will scroll up to the next higher range when the reading displayed exceeds full scale. The probe will scroll down to the next lower range when the reading displayed is -14 dB (20%) of the full scale reading for the current range. This will put the reading at approximately 2/3 of full scale of the next lower range. See the following *Auto Range Readings Table* and *Auto Range Flow Diagram*.

Range	-20dB of full scale	Reading after scroll down	-14dB of full scale; scroll down point	Full scale scroll up point	Reading after scroll up	Full scale reading
1	1 mA	7.2 mA		10 mA		10 mA
2	3.16 mA	20 mA	7.2 mA	31.6 mA	10 mA	31.6 mA
3	10 mA	72 mA	20 mA	100 mA	31.6 mA	100 mA
4	31.6 mA	200 mA	72 mA	316 mA	100 mA	316 mA
5	100 mA		200 mA		316 mA	1000 mA

### Auto Range Readings Table

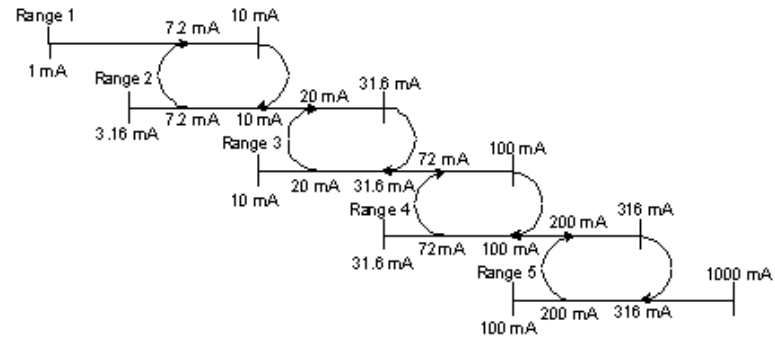

### Auto Range Flow Diagram

#### 6. Select averaging.

Use the HI-4416 to select **Instantaneous Readings** or **One-Second Averaging**. The HI-3702 collects a measurement approximately seven times per second. When the X-axis is selected, each measurement is sent to the display. When the Y-axis is selected, the one-second average of the measurements is displayed. The averaging algorithm stores the seven most recent measurements. Each time a measurement is taken, the algorithm drops the oldest value, adds in the new value, and then recalculates the average and sends the new average value to the display.

#### 7. Attach the clamp-on current sensor.

Place the clamp-on current sensor on the arm or leg of the body under test and close the buckle. For accurate measurements, verify that nothing interferes with complete closure of the clamp-on current sensor. Make sure no clothing is caught between the coplanar surfaces of the ferrite core material or the aluminum housing.

Displayed readings that are less than 10% of the full scale reading for the selected range are not valid. When **Range 1** or **Autorange** is selected and there is no current passing through the current meter, a noise floor reading will display. This is a normal operating condition.

## Computer Controlled Data Logging

---

The HI-3702 is connected for data logging as shown.

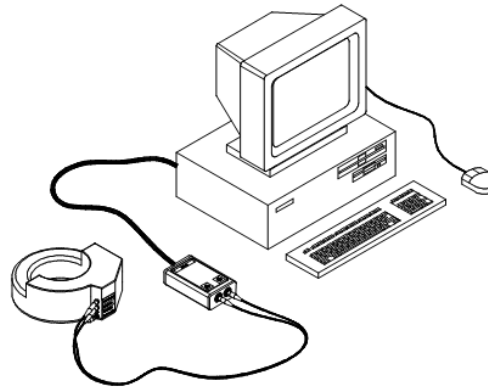

Software is available for the personal computer that simulates the HI-4416. For information on using the HI-4416 for data logging, see the HI-4416 manual.

Use the optional RS-232 cable assembly (part #H-2239615) to connect the HI-3702 to the HI-4413P Fiber Optic Modem. This provides direct input of HI-3702 data into a personal computer or other data logging device.

## Battery Charging

---

### CAUTION

Never attempt to recharge a non-rechargeable battery.



If the battery has been through its normal life span of approximately 1000 charge/discharge cycles, return the HI-3702 to ETS-Lindgren for battery replacement and recalibration. For more information, see *Battery Maintenance* on page 10.

1. Turn off the HI-3702.
2. Connect the battery charger to an AC outlet.

3. Plug the charger jack completely into the CHARGE connector on the clamp-on current sensor.

Allow approximately one hour for a full charge cycle. When charging is complete, the battery charger automatically goes into a trickle charge. It will remain in trickle charge mode until disconnected from the HI-3702.

4. When the charge cycle is complete, remove the charger jack from the CHARGE connector on the clamp-on current sensor.
5. Unplug the battery charger from the AC outlet.
6. Use the HI-4416 to verify that the battery is charged to approximately 3.8 VDC.

See *Series H-491198-36 Battery Charger* on page 27 for complete information on the battery charger.

### **Error Codes**

---

If an error occurs, the probe will respond with one of the following strings. These strings begin with a colon and end with a carriage return.

E01      Communication error (for example, overflow)

E02      Buffer full error; too many characters contained between the start character and carriage return sequence

E03      Received command is invalid

E04      Received parameter is invalid

E05      Hardware error (for example, EEPROM failure)

E06      Parity error

E9        Received command is invalid

This page intentionally left blank.

## 5.0 Functional Theory of Operation

Following is a functional theory of operation for the HI-3702 Clamp-on Induced Current Meter. The objective is to enhance user understanding of the theory behind the design to aid with the operation and maintenance of the HI-3702.

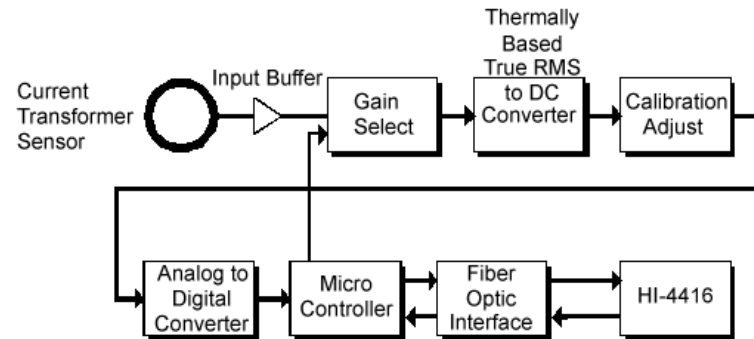

The HI-3702 is designed to measure RF induced current flowing through the ankles or arms of the body under test, even while walking or climbing. The fiber optically coupled readout/control unit does not perturb the measured RF field or the current distributions. The sensor is a ferrite split core current transformer. The signal generated by the sensor is amplified by 10 dB to 50 dB depending on the range that is selected. There is 20 dB of linearity for each range. This signal is applied to a True RMS Thermal RMS to DC Converter. The DC voltage output of the True RMS Thermal RMS to DC Converter is applied to a 12 bit A/D converter. This digital representation of the DC voltage is read by the microprocessor, converted to a number that is representative of current being sensed, and transmitted through the fiber optic interface to the HI-4416 Digital Readout/Control Unit.

This page intentionally left blank.



## Appendix A: Warranty

---



See the *Product Information Bulletin* included with your shipment for the complete ETS-Lindgren warranty for your HI-3702.

### DURATION OF WARRANTIES FOR HI-3702

All product warranties, except the warranty of title, and all remedies for warranty failures are limited to one year.

Product Warranted	Duration of Warranty Period
HI-3702 Clamp-on Induced Current Meter	1 Year
Series H-491198-36 Battery Charger	1 Year

This page intentionally left blank.

## Appendix B: Series H-491198-36 Battery Charger

---



The HI-3702 Clamp-on Induced Current Meter contains a nickel-cadmium (NiCd) battery, and uses the Series H-491198-36 Battery Charger.

### SAFETY PRECAUTIONS

---

#### CAUTION

Before operating the Series H-491198-36 Battery Charger, see *General Safety Considerations* on page v.

### INTRODUCTION

---

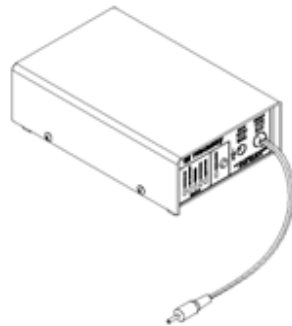

The **Series H-491198-36 Battery Charger** is a dual power source battery charger. It charges 3.6 Volt 1400 mAh NiCd batteries and is powered by 120-240 VAC line power or 12.5 VDC. The H-491198-36 charger uses a  $-(dV)/(dT)$  negative delta V technique to determine when the battery is fully charged, which is typically one hour. With this technique, the charge state of the battery has no effect other than shortening the charge time.

Housed in a rugged enclosure, power enters the battery charger through a power entry module, which contains the fuses, or an optional cigarette lighter plug adapter. The front face of the battery charger displays LEDs that provide the operating status. The battery charger connects to the device being charged through a short cord terminated with a power jack.

An integrated circuit within the battery charger monitors the battery voltage and controls the charging functions according to the charge state of the battery.

## CHARGING A BATTERY

---

### **CAUTION**

Never attempt to recharge a non-rechargeable battery.

For the steps to charge a battery, see page 20.

## CHARGING INDICATORS

---

The following LEDs are located on the front of the battery charger:

- **POWER ON** (green)—Indicates the battery charger is connected to the AC power source.
- **NO BATTERY** (amber)—Indicates the battery charger does not detect a battery.
- **PENDING** (amber)—Indicates the battery charger detects a battery.  
Before fast charging can begin, the battery voltage must fall within predetermined acceptable limits. A pulse-trickle charge is provided to bring a depleted battery to a valid charge prior to fast charge.
- **CHARGING** (amber)—Indicates the voltage pre-qualification condition has been met, and fast charge has started.
- **COMPLETE** (green)—Indicates a fast charging peak voltage is detected. The Field Probe can remain connected to the battery charger indefinitely while in this maintenance mode.

## SPECIFICATIONS

Power	
<b>Main:</b>	IEC filtered AC power input module 110-240 VAC, 500 mA max, 50-100 Hz
<b>Alternate:</b>	Automobile cigarette lighter to 2 mm power plug adapter cord, 12.5 Vdc, 100 mA
<b>Fuses:</b>	250 Volt, 1.0 Amp, Type T (5 mm x 20 mm)
Output	
<b>Open Circuit Voltage:</b>	15 Vdc
<b>Fast Charge Pending Current:</b>	60 mA
<b>Fast Charge Current:</b>	1400 mA
<b>Pulsed Trickle Charge Current:</b>	50 mA
<b>Output Voltage (During Fast Charge):</b>	3–6 Vdc
Battery	
<b>NiCd Battery:</b>	<ul style="list-style-type: none"> <li>• 3.6 Volt 3 Cell NiCd Battery, 1400 mAH (rapid charge cells, 1.2 Volts/cell)</li> <li>• ETS-Lindgren Part #491038</li> </ul>

Environmental	
Operating Temperature:	10°C–40°C (50°F–104°F)
Humidity:	5% to 95% relative humidity, non-condensing

### MAINTENANCE RECOMMENDATIONS

---

- Operate the battery charger with care.
- There are no user serviceable parts inside the battery charger. Opening the battery charger housing may void your warranty.

### REPLACING THE FUSE

---

#### **CAUTION**

**Disconnect the battery charger from power before replacing a fuse.**

If the battery charger fails to operate, check for a blown fuse inside the power entry module. A blown fuse must be replaced with the same value and type of fuse, or an unsafe condition may result. Use only 250 Volt, 1.0 Amp, Type T (5 mm x 20 mm) fuses.

To replace a fuse:

1. Two fuses are located in the fuse drawer in the power input module. Use a screwdriver to open the drawer.
2. The fuse towards the outside of the drawer is the spare. Remove the spare fuse from the module.

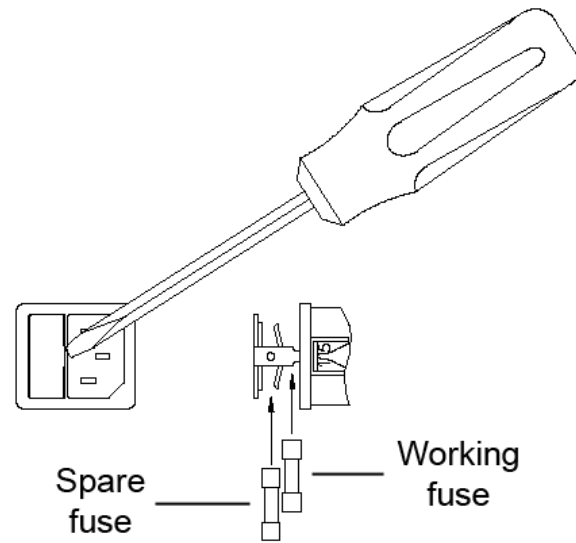

3. Replace the blown fuse with the spare fuse.
4. Slide the fuse drawer back into the module. Make sure that the drawer snaps securely into its locked position.

This page intentionally left blank.



## Appendix C: EC Declaration of Conformity

### HI-3702 CLAMP-ON INDUCED CURRENT METER



#### Declaration of Conformity

We, ETS-Lindgren, L.P., 1301 Arrow Point Drive, Cedar Park, TX, 78613, USA, declare under sole responsibility that the:

**Model/Part Number:** HI-3702  
**Model/Part Name:** Induced Current Meter  
**Date of Declaration:** 30 June, 1999

to which this declaration relates, meets the requirements and is in conformity with the relevant EC Directives listed below using the relevant section(s) of the following EC harmonized standards and other normative documents;

**Applicable Directive(s):**

Electromagnetic Compatibility Directive (EMC), 89/336/EEC and its amending directives

**Applicable harmonized standard(s) and/or normative document(s):**

EN 50082-1:1992 Electromagnetic compatibility - Generic immunity standard Part 1: Residential, commercial and light industry

EN 55011:1991- Group 1 Class B, Limits and methods of measurement of radio disturbance characteristics of industrial, scientific, and medical (ISM) radio-frequency equipment

**Authorized Signatories:**

ETS-Lindgren L.P.  
Bryan Sayler, General Manager

ETS-Lindgren L.P.  
James C. Psencik, Vice President of Engineering

The authorizing signatures on this Declaration of Conformity document authorizes ETS-Lindgren, L.P. to affix the CE mark to the indicated product. CE marks placed on these products will be distinct and visible. Other marks or inscriptions liable to be mistaken with the CE mark will not be affixed to these products.

ETS-Lindgren, L.P. has ensured that technical documentation shall remain available on premises for inspection and validation purposes for a period ending at least 10 years after the last product has been manufactured.

## SERIES H-491198-36 BATTERY CHARGER



### Declaration of Conformity

We, ETS-Lindgren, L.P., 1301 Arrow Point Drive, Cedar Park, TX, 78613, USA, declare under sole responsibility that the:

**Model/Part Number:** H-491198-36/ H-491198-48/ H-491198-72

**Model/Part Name:** Battery Charger series

**Date of Declaration:** 30 June, 1999

to which this declaration relates, meets the requirements and is in conformity with the relevant EC Directives listed below using the relevant section(s) of the following EC harmonized standards and other normative documents;

**Applicable Directive(s):**

Low Voltage Directive (LVD), 73/23/EEC and its amending directives

Electromagnetic Compatibility Directive (EMC), 89/336/EEC and its amending directives

DENAN- Electrical Appliance and Material Safety Law

**Applicable harmonized standard(s) and/or normative document(s):**

EN 50082-1:1992 Electromagnetic compatibility - Generic immunity standard Part 1: Residential, commercial and light industry

EN 55011:1991- Group 1 Class B, Limits and methods of measurement of radio disturbance characteristics of industrial, scientific, and medical (ISM) radio-frequency equipment

EN 60335-1:1995 Specification for safety of household and similar electrical appliances, General requirements

EN 60335-2-29: Part 2, 1991 Safety of household and similar electrical appliances-Particular requirements for battery chargers

EN 61010-1: Safety requirements for electrical equipment for measurement, control, and laboratory use

**Authorized Signatories:**

ETS-Lindgren L.P.  
Bryan Saylor, General Manager

ETS-Lindgren L.P.  
James C. Psencik, Vice President of Engineering

The authorizing signatures on this Declaration of Conformity document authorizes ETS-Lindgren, L.P. to affix the CE mark to the indicated product. CE marks placed on these products will be distinct and visible. Other marks or inscriptions liable to be mistaken with the CE mark will not be affixed to these products.

ETS-Lindgren, L.P. has ensured that technical documentation shall remain available on premises for inspection and validation purposes for a period ending at least 10 years after the last product has been manufactured.