

HI-3627

ELF Magnetic Field Meter

User Manual



ETS-Lindgren Inc. reserves the right to make changes to any products herein to improve functioning or design. Although the information in this document has been carefully reviewed and is believed to be reliable, ETS-Lindgren does not assume any liability arising out of the application or use of any product or circuit described herein; nor does it convey any license under its patent rights nor the rights of others. All trademarks are the property of their respective owners.

© Copyright 1992–2016 by ETS-Lindgren Inc. All Rights Reserved. No part of this document may be copied by any means without written permission from ETS-Lindgren Inc.

Trademarks used in this document: The *ETS-Lindgren* logo is a registered trademark of ETS-Lindgren Inc.

Revision Record

HI-3627 MANUAL, Elf Magnetic Field Meter | Part # H-600047,
Rev. B

Revision	Description	Date
	Preliminary Release	May 1992
	Release	June 1992
A	Added CE Label	October 1997
B	Revised contents to: <ul style="list-style-type: none">• Comply with ETS-Lindgren style guidelines• Meet current standards	April 2016

Table of Contents

Notes, Cautions, and Warnings	6
Safety Information	6
1.0 Introduction.....	9
ETS-Lindgren Product Information Bulletin	10
2.0 Maintenance.....	11
Battery Replacement	11
3.0 Specifications	13
4.0 Operation.....	17
Quick Start.....	17
Controls, Indicators, and Connectors	17
Recorder Output	18
Low Battery Indication	20
Recharging	20
5.0 Making Measurements.....	21
6.0 Example Applications of the HI-3627	23
Mapping Power Lines	23
Locating and Mapping Underground Cables	24
Residential Measurements Surveys	24
Residential Ground Currents	26
Ground Faults	26
Pipe Inspections	26
7.0 Principle of Operation.....	29
Probe	29
Input Signal Conditioning.....	29
Filter Section.....	29
RMS Circuitry.....	31
Information Processing.....	31
Power Supply.....	31
8.0 Calibration.....	33

9.0 References	35
Appendix A: Warranty.....	37
Duration of Warranties.....	37
Appendix B: EC Declaration of Conformity.....	39

This page intentionally left blank.

Notes, Cautions, and Warnings



Note: Denotes helpful information intended to provide tips for better use of the product.



Caution: Denotes a hazard. Failure to follow instructions could result in minor personal injury and/or property damage. Included text gives proper procedures.



Warning: Denotes a hazard. Failure to follow instructions could result in SEVERE personal injury and/or property damage. Included text gives proper procedures.



Note: See the ETS-Lindgren *Product Information Bulletin* for safety, regulatory, and other product marking information.

Safety Information



Refer to Manual: When product is marked with this symbol, see the instruction manual for additional information. If the instruction manual has been misplaced, download it from www.ets-lindgren.com, or contact ETS-Lindgren Customer Service.



High Voltage: Indicates presence of hazardous voltage. Unsafe practice could result in severe personal injury or death.



High Voltage: Indicates presence of hazardous voltage. Unsafe practice could result in severe personal injury or death.



Protective Earth Ground (Safety Ground): Indicates protective earth terminal. You should provide uninterruptible safety earth ground from the main power source to the product input wiring terminals, power cord, or supplied power cord set.



Laser Warning: Denotes a laser (class 1M) is part of the operating system of the device.



Waste Electrical and Electronic Equipment (WEEE) Directive: (European Union) At end of useful life, this product should be deposited at an appropriate waste disposal facility for recycling and disposal. Do not dispose of with household waste.



Recyclable Products: This product includes rechargeable batteries. At end of useful life, please recycle the used batteries, or dispose of them safely and properly. Many cities collect used batteries for recycling or disposal. You may contact your local waste disposal agency for information on battery recycling and disposal.

This page intentionally left blank.

1.0 Introduction

The HI-3627 ELF Magnetic Field Meter is designed to measure the flux density of magnetic fields in the frequency range of 5 Hz to 2 kHz. The HI-3627 finds application in the measurement of magnetic fields associated with electric power lines and electrically operated appliances.

The HI-3627 is a three axis flux density meter designed to be responsive to either sinusoidal or complex magnetic field waveforms. It computes the root-mean-square (RMS) value of magnetic flux density and directly displays it on an analog meter. The sensor consists of three multiturn loops connected to the instrumentation readout package via a 1.2 meter long cable. The microprocessor in the meter continually computes the magnitude of the field independent of the probe orientation. This allows quick assessment of the actual flux density value while conveniently holding the instrument for easy meter reading. This feature makes the HI-3627 especially useful for rapid, large area surveys of magnetic fields.

The field sensor is electrically shielded making the response of the HI-3627 immune to most electric field effects. No interference is caused by ambient electric fields such as might be found beneath high voltage, overhead electric power lines or nearby radio or television stations.

The HI-3627 has a wide dynamic measurement range. This provides for readings from 0.2 milligauss to 20 gauss. This large dynamic range makes the HI-3627 convenient for measurement of ambient residential magnetic fields as well as high level fields found near high current carrying conductors or electrical machinery.

ETS-Lindgren Product Information Bulletin

See the ETS-Lindgren *Product Information Bulletin* included with your shipment for the following:

- Warranty information
- Safety, regulatory, and other product marking information
- Steps to receive your shipment
- Steps to return a component for service
- ETS-Lindgren calibration service
- ETS-Lindgren contact information

2.0 Maintenance



CAUTION: Before performing any maintenance, follow the safety information in the ETS-Lindgren *Product Information Bulletin* included with your shipment.



WARNING: Maintenance of the HI-3804 is limited to external components such as batteries, cables, or connectors.



To prevent electrical shock, do not remove cover.

Warranty may be void if the housing is opened.



If you have any questions concerning maintenance, contact ETS-Lindgren Customer Service.

Battery Replacement

The battery pack used in the HI-3627 Magnetic Field meter is a commonly available NiCad battery pack (ETS-Lindgren part number H-491044, 9.6 volt, 600 mA, or equivalent). In the event of battery failure, a new battery can be obtained from ETS-Lindgren or from a local source. To replace the battery pack:

1. Remove back cover of the meter.

Back cover is fastened by six screws that can be found around the lip of the front panel. The battery is retained by two more screws and a metal strap that holds the battery in place. Use a #1 Phillips screw driver for these operations.

2. Unplug the battery
3. Remove battery retainer.

To replace the battery, reverse these steps.



CAUTION: Never short the output of a NiCad battery (even a discharged battery). The resultant currents will be large. This will cause the lead wires to become extremely hot which can cause severe burns and/or fire.

Service Procedures

CONTACTING ETS-LINDGREN



Note: Please see www.ets-lindgren.com for a list of ETS-Lindgren offices, including phone and email contact information.

SENDING A COMPONENT FOR SERVICE

For the steps to return a system or system component to ETS-Lindgren for service, see the *Product Information Bulletin* included with your shipment.

CALIBRATION SERVICES AND ANNUAL CALIBRATION

See the *Product Information Bulletin* included with your shipment for information on ETS-Lindgren calibration services.

3.0 Specifications

Frequency Response	30 Hz -3 dB (see note)
	2000 Hz -3 dB
	< 30 Hz Falling 80 dB/decade (see note)
	> 2000 Hz Falling 40 dB/decade



Note: The frequency response is switchable to 5 Hz.

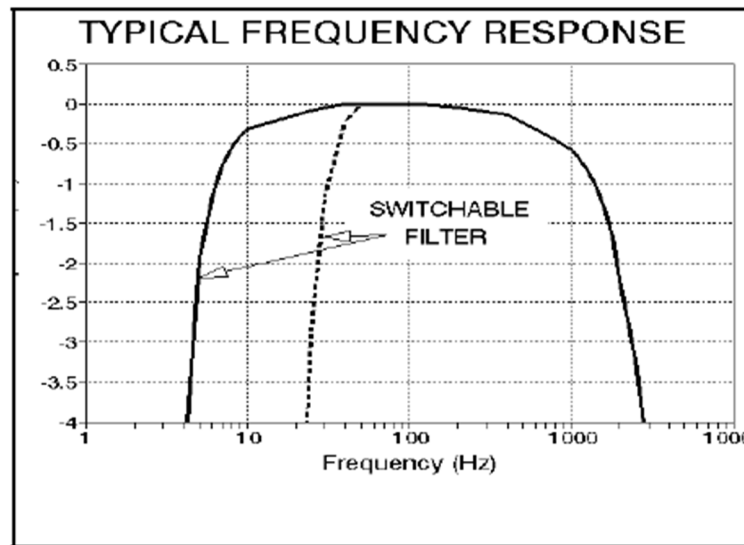

Figure 3-1: Typical Frequency Response

Sensor	External, three axis multi-turn loop, with inside diameter of 110 mm and outside diameter of 116 mm; loop area 0.010 m ² . Cable length is 1.2 meters
Detector Response	True RMS field indication for accurate measurement of non-sinusoidal waveforms.
Sensitivity	Full scale ranges of: <ul style="list-style-type: none"> • 2 mG • 20 mG • 200 mG • 2 G • 20 G
Accuracy	± 5 % at calibration frequency
Power	One 9.6 volt NiCad battery
Battery Life	Approximately 30 Hrs. continuous operation (new battery with a full charge)
Linearity (see note)	± 2% Full Scale



Note: The instrument is calibrated using a one meter diameter pair of Helmholtz coils for establishing an accurately known magnetic field flux density. A precisely controlled and measured sinusoidal current is driven through the Helmholtz coils and, based on the dimensions of the coils, the magnetic field flux density between the coils is calculated.

While the HI-3627 indicates magnetic flux density (B) in units of milligauss, the flux density in microtesla or magnetic field strength (H) in milliamperes per meter may be obtained via the following relations:

$$1 \text{ mG} = .1 \text{ microtesla } (\mu\text{T})$$

$$1 \text{ mG} = 80 \text{ milliamperes per meter (mA/m)}$$

This page intentionally left blank.

4.0 Operation



CAUTION: Before placing into operation, follow the safety information in the ETS-Lindgren *Product Information Bulletin* included with your shipment.

Quick Start

- Step 1. Plug sensor into multi-pin connector at top end of the meter.
- Step 2. Turn the meter on by rotating the range selector switch one position clockwise. Note: the battery low LED will flash momentarily as the meter is turned on.
- Step 3. Verify that the over range LED and the battery LED are not illuminated.
- Step 4. Make measurements with the range selector switch set for the maximum reading without an over range indication.

Controls, Indicators, and Connectors

The HI-3627 is housed in a rugged aluminum case with a detachable probe. The unit is shipped in a convenient carrying case with foam cutouts which accommodate the meter, probe and the optional accessories offered with the meter.

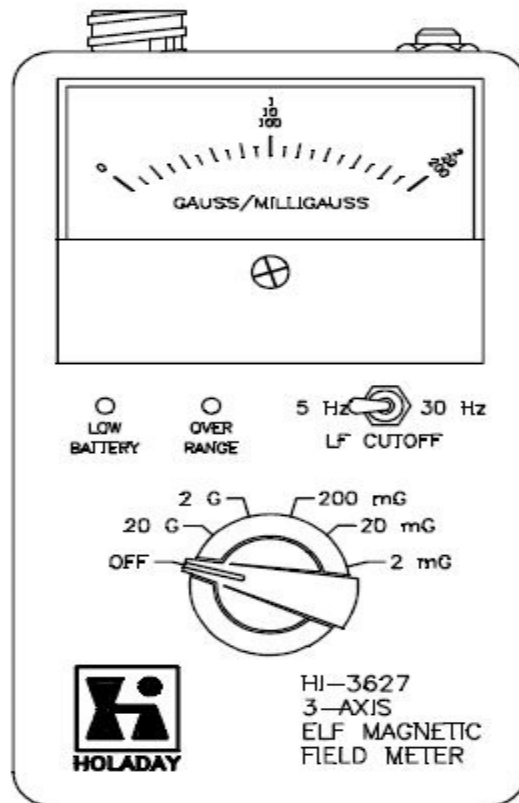

Figure 4-1: Meter

Recorder Output

The HI-3627 Magnetic Field Meter has a recorder output. The recorder output is a voltage signal (0-5 VDC) proportional to the needle deflection on the meter. This output can be used to drive a chart recorder, data logger, or other device to display the indicated field reading on the instrument.

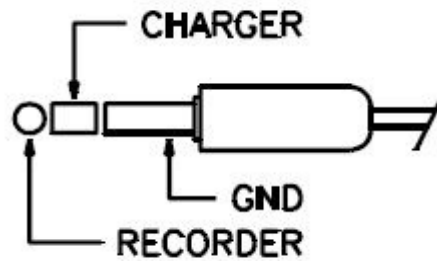

Figure 4-2: Recorder Output

The connection for the recorder output is made through the same connector as the battery charger (refer to figure 4-2). This is a two circuit connector (jack) that mates with a standard 1/4 inch stereo phone plug. The ring of the phone plug is reserved for battery charger input and the tip is connected to the recorder output. The shaft of the plug is the common ground. A diode in the battery charging circuit keeps the battery voltage from being applied to the recorder output when a plug is inserted into the jack.

The recorder output comes directly from the circuit driving the meter movement. The maximum current available to the recorder output jack is 1 milliampere (5000 ohm minimum recorder output load). A lower impedance recorder output load will affect the accuracy of both the meter reading and the signal to the recorder output.

The meter movement and the recorder output are driven by a PWM (pulse width modulator). This leads to a small amount of ripple on the recorder output, typically 50 mV at 40 Hz.

Low Battery Indication

The HI-3627 Magnetic Field Meter includes a "Low Battery" indicator. This is an LED mounted on the front panel (refer to figure 4.1). It is normal for the LED indicator to briefly blink when turning the switch to various ranges and when turning the instrument off.

If the "Low Battery" indicator remains on during operation, the battery must be recharged. When the "Low Battery" LED lights, about 10 minutes of useful operation remains. This relatively short time is due to the output voltage of a NiCad battery remaining relatively flat until the battery is almost completely discharged, and then dropping very rapidly.

Recharging

Recharge the battery with the standard trickle charger (P/N H-491063-02). Recharging a fully discharged unit will take 15 hours to complete.

The standard charger provided with the HI-3627 is a trickle charger. It works by charging the battery with relatively low current. The charger can be left connected to the meter indefinitely without causing severe damage, although some memory effects may result. NiCad "memory" sometimes occurs when the battery is kept at full or nearly full charge without intervening discharge cycles. The effect is to reduce the apparent capacity of the battery and shows up as a short operating time before recharging is required. This effect can be minimized by occasionally operating the meter until the "Low Battery" LED indicates recharging is necessary.

5.0 Making Measurements

To begin making field measurements, plug the probe into the meter. Turn the range switch to the right, increasing the instrument's sensitivity until an upscale reading on the meter is observed. The readings will be most accurate when maximum deflection is observed. When an over range indication does occur, the next larger range should be selected. It should be noted that the meter movement is protected against deflection past the top of scale. Therefore, the "Over Range" LED must be relied on to indicate an over range condition.

It is not necessary to rotate the sensor to obtain a maximum indication on the meter. The value of flux density is obtained by taking three orthogonal measurements of the field. In this case, the sensor has three separate coils oriented in three mutually perpendicular directions around a fixed point. The resultant flux density is then found by calculating the root-sum-squared value from the individual RMS readings for each axis.

For area surveys of ELF fields, the 30 Hz cutoff will be more useful. When the 5 Hz frequency cutoff is selected, the unit will be sensitive to movement of the sensor. This is due to the earth's constant magnetic field (approximately 500 mG). When the sensor is accelerated or rotated within this constant field, there will be an output from the sensor at a frequency corresponding to the movement. Consequently, during such movement, the meter will typically show significant upscale indications. The 5 Hz frequency cutoff setting is primarily useful for measurements at fixed coil positions such as near VDTs.

This page intentionally left blank.

6.0 Example Applications of the HI-3627

Mapping Power Lines

Magnetic fields near power lines can be easily measured with the HI-3627. An approach commonly used to characterize power line fields is to measure the flux density along a straight line which passes perpendicular to the power line. Generally, readings are first taken along the length of a span of the power line to identify the point at which the greatest flux density exists. Then at this point take the readings perpendicular to the power line. Take readings every five to ten feet. A magnetic field flux density profile can then be developed. This method is outlined by the Institute of Electrical and Electronics Engineers (IEEE) in the American National Standards Institute (ANSI) standard 644-1987 (1).

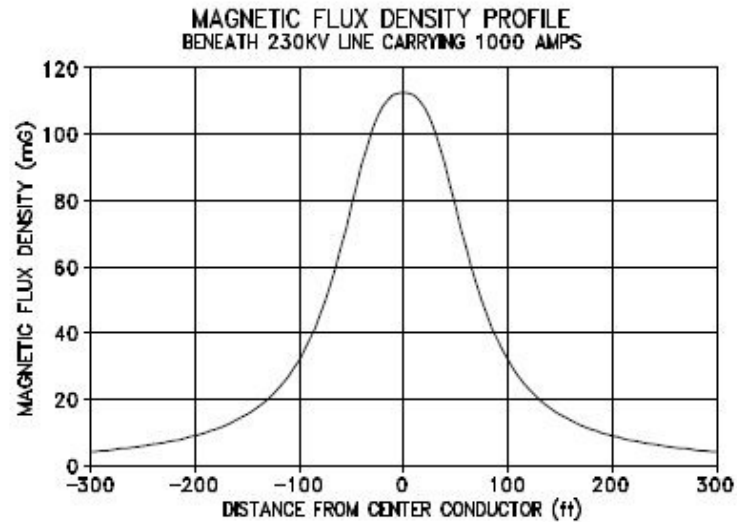

Figure 6-1

Figure 6.1 is an example of a theoretical profile obtained for a 230 kilovolt (kV), single circuit line with 1000 amperes flowing in the conductors. For the particular case presented, the conductors are situated 50 feet above ground and are spaced 32 feet apart. The actual profile shape is dependent on the exact geometry of the power line, its height above ground and the current flowing in the line. The flux density peaks near a point beneath the conductors of the line.

Locating and Mapping Underground Cables

The HI-3627 with its omni-directional response is an effective and easy to use device for locating buried current carrying bodies. The procedure is quite simple. Hold the probe near the ground at a constant height and walk toward the highest field reading. A peak value usually means that you are standing above the current carrying body.

A similar approach may be used for measuring the flux density produced by buried lines. In this case, the area must be explored by walking about with the meter until the region of maximum flux density is found. Then, as in mapping power lines, you would make straight line passes perpendicular to the buried cable recording readings at fixed intervals.

Residential Measurements Surveys

Magnetic fields found in home environments are highly variable, depending on location within the home. This variability is strongly related to the distribution of the wiring in the home, the location of electrical appliances and, sometimes, the location of plumbing lines or other metallic structures within the ground which may form low resistance paths for electrical ground return currents. Establishing what the ambient magnetic field environment is in a home usually requires numerous measurements throughout the home, with at least one measurement within each room. Normal practice would include at least one field measurement taken near the center of each room. A more thorough approach would include five measurements in each room, one at the center and one near each corner of the room. A reasonable

technique is to position the sensor at a point approximately one meter from each room corner for the flux density measurement. This avoids, to an extent, placing the sensor immediately next to wiring which may be hidden within the walls of the room and which may yield unrealistically high values of flux density compared to what most individuals within the room might be exposed. A possible protocol for making the measurements is outlined in the California Department of Health Services paper on suggested protocol for measuring 60 Hz magnetic fields in residences (3).

Surveys of the areas near electrical appliances will usually reveal higher values of flux density due to the currents flowing within motors or heating elements. This may influence the location of beds, and other locations of extended occupancy. In characterizing the magnetic fields near obvious sources, such as appliances, it is often helpful to measure and record the flux density value at intervals of a few inches (or centimeters) beginning near the surface of the device. These data will help provide a perspective on the spatial extent of the elevated field levels and the significance of the levels relative to other values determined elsewhere within the home. Field measurements should take into account the likelihood that individuals may have access to areas where measurements are contemplated.

Because 60 Hz magnetic fields produced by the use of electricity within the home are dependent on the magnitude of current flowing within wires or the operation of appliances, flux densities will be seen to vary with time, being greater when more electrical power is being used. For example, when heating or air conditioning systems turn on or the compressor within a refrigerator cycles on, the flux density will increase. Measurements must take this condition into account. It is recommended when taking measurements in a room, the meter be watched for a period of time to observe for fluctuations in the indicated value of flux density. After some experience, it may be possible to relate the observed fluctuations to various uses of electricity within the room.

Residential Ground Currents

A phenomenon, which recently received attention in regard to residential magnetic fields, is the flow of earth currents via plumbing lines or telephone cables buried beneath the home. In some cases, it has been noted that 60 Hz magnetic fields exist within a home, even when the home is not using any electrical power (the circuit breakers have all been turned off at the main electrical service box of the home).

This observation has, in some cases, been related to the flow of currents beneath the home on pipes or cables. It is not unusual for currents related to other neighbors' use of electricity to flow back to the electrical supply via low resistance paths. These are formed by metal plumbing pipes or wires used for telephones as opposed to the electrical system neutral wire. In such cases, it is possible to measure magnetic flux densities within the home even though the power to the home has been shut off.

Ground Faults

As mentioned earlier, current can exist in pipes and heating ducts or anything metal in the house. This gives rise to an interesting application for the HI-3627; detecting leakage currents from appliances. For example it was noted that the fields around a water pipe leading from a dishwasher changed dramatically when the dishwasher was run. It was later found that the dishwasher was defective and allowed excessive ground currents to flow. The same principles apply to industrial and power distribution situations.

Pipe Inspections

It was noted that the buried pipes leading to fire hydrants tended to concentrate the currents flowing in the ground from power distribution leakages. The field from this current could be detected and measured. It was also noted that the field would vary uniformly as the operator walked along the pipe. The field would, however, exhibit significant variations at points on the pipe where there was a break or a large

amount of corrosion. In this way a single operator with very little equipment could inspect a large section of pipe for possible failures in a very short period of time. This, of course, is a singular example that only worked because of very unusual circumstances, but it does show the versatility of this easy to use field meter.

This page intentionally left blank.

7.0 Principle of Operation

The circuitry of the HI-3627 can be divided into six sections; the probe, input signal conditioning, filter section, RMS calculation, information processing and power supply. Each of these is discussed in the following sections (see Figure 7.1).

Probe

The probe consists of three concentric shielded coils aligned with their axes perpendicular to one another. The electrostatic shield of each coil is isolated from that of the other. The shields are connected together at a single point at the base of the sphere defined by the coils. The signals from each coil are brought to the meter through a shielded twisted pair cable with its shield connected to the coil shield common point.

Input Signal Conditioning

The output voltage of a coil varies with the frequency of the applied magnetic field. A single pole low pass filter is added to the output of each coil to flatten the frequency response and provide impedance matching. The input signals are then passed through a programmable gain amplifier stage that provides the necessary amplification for the individual ranges. The signals then pass to the filter section.

Filter Section

Each channel is filtered separately. The first stage is a two pole Butterworth low pass filter at 2000 Hz. A Butterworth filter attenuates the signal by 3 dB at the cutoff frequency with attenuation in the stop band and no ripple in the pass band. The output of the low pass filter is fed into two 4 pole high pass filters. The cutoff frequencies on these filters are 5 Hz and 30 Hz corresponding to the low frequency cutoff selections.

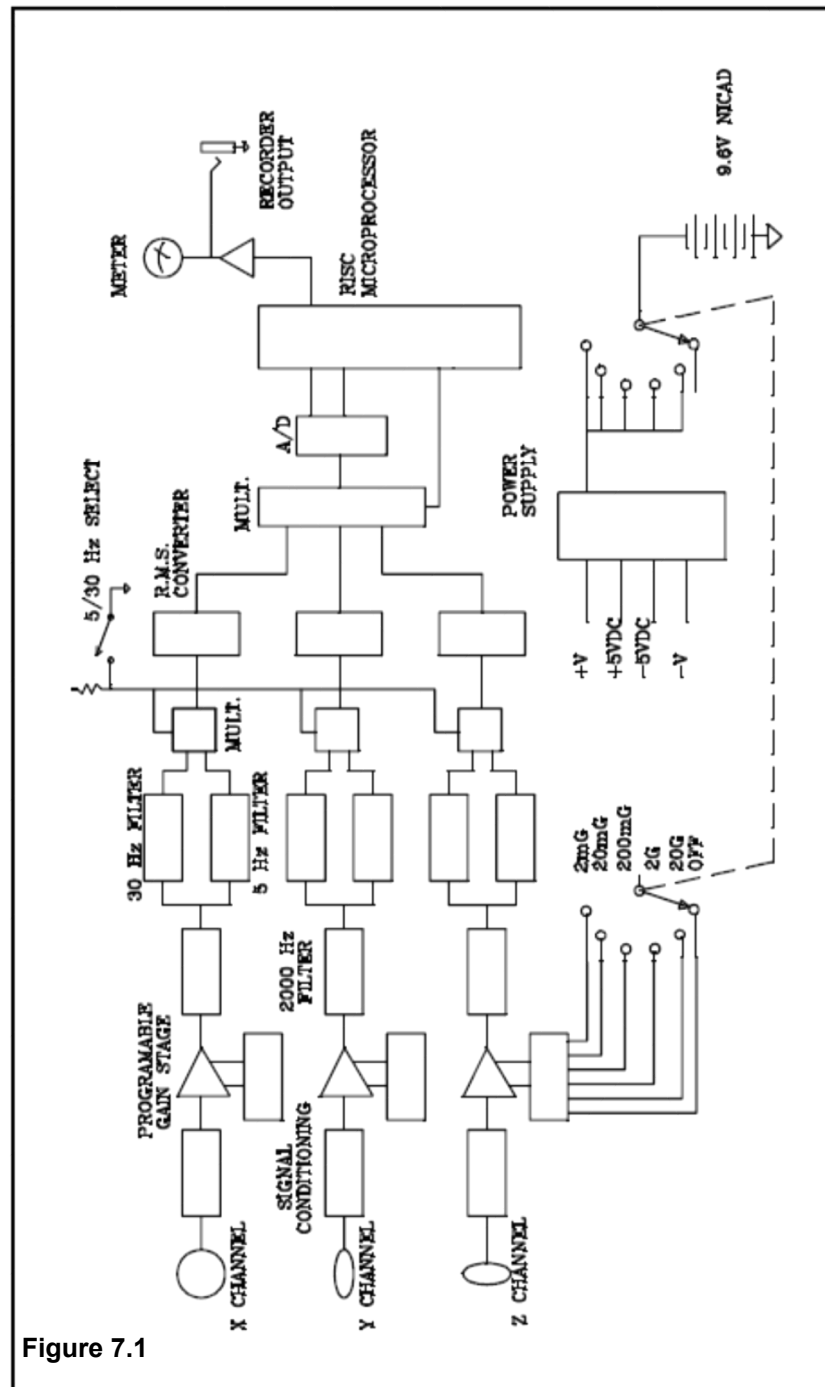

Figure 7.1

The front panel switch controls an analog multiplexer which selects the proper filter output.

RMS Circuitry

The signal from each filter is fed into one of three true RMS converter integrated circuits, one for each channel. The time response of the RMS converter is selected to give acceptable step input response time while yielding minimal RMS conversion errors at 5 Hz. This time constant is around 500 msec. This is the predominant time constant of the meter.

Information Processing

The outputs of the three true RMS converters are combined through vector addition to calculate the resultant field magnitude. This computation is computed by a processor and an A/D converter. The meter is driven by outputs configured as a PWM (Pulse Width Modulator). The processor performs an A/D conversion on the signal from each axis by programming an analog multiplexer into a 12 bit A/D converter. The digital values are then squared, summed and the square root of the sum is calculated. This result is used to set the duty cycle of the PWM output which drives the meter movement. The output frequency of the PWM is about 30 Hz. This frequency is too high to show on the analog meter, but can be detected as about 50 mV of ripple on the recorder output.

Power Supply

Power is supplied to the HI-3627 by a NiCad battery. The NiCad battery chosen for this application is a common type. The current consumption of the instrument is relatively low with the operating life being greater than 30 hours of continuous operation. During typical daily operation, with intermittent use, the time between recharges will be greater. The individual voltages supplied to the circuitry are derived from the battery voltage directly, supplied through series pass regulators and from a switched capacitor voltage inverter.

This page intentionally left blank.

8.0 Calibration

The HI-3627 is calibrated using a one meter diameter Helmholtz coil. Each axis is individually calibrated. Calibration is performed at 60 Hz at levels of 100 mG, 1 G, and 10 G. All calibrations are traceable to NIST. The frequency response of each axis is checked in all meters.

The recommended recalibration interval is one year. ETS-Lindgren offers complete recalibration services which comply with MIL-STD 45662A.

This page intentionally left blank.

9.0 References

(1) IEEE Standard Procedures for Measurement of Power Frequency Electric and Magnetic Fields from AC Power Lines. ANSI/IEEE standard 644-1987. Published by The Institute of Electrical and Electronics Engineers, Inc., 345 East 47th Street, New York, NY 10017. Approved November 17, 1986.

(2) Swedish National Board for Measurement and Testing, Test Methods for Visual Display Units- Visual Ergonomics and Emission Characteristics. MPR 1990:8, 1990-12-01, National Board for Measurement and Testing, Box 878, S-501 15 Bors, Sweden.

(3) Electric and Magnetic Field Measurements and Possible Effects on Human Health from Appliances, Power Lines, and Other Common Sources. Special Epidemiological Studies Program, California Department of Health Services, 2151 Berkeley Way, Room 704, Berkeley, Ca. 94704 (415)540-2669

This page intentionally left blank.

Appendix A: Warranty



Note: See the *Product Information Bulletin* included with your shipment for the complete ETS-Lindgren warranty for your HI-3627 Elf Magnetic Field Meter.

Duration of Warranties

All product warranties, except the warranty of title, and all remedies for warranty failures are limited to one year.

Product Warranted	Duration of Warranty Period
HI-3627 ELF Magnetic Field Meter	1 year

WARNING

SPECIAL CAUTION IS ADVISED WHEN WORKING IN ENVIRONMENTS WHERE CONTACT WITH HIGH VOLTAGE OR HIGH CURRENT CIRCUITS OR APPARATUS IS POSSIBLE. THIS IS PARTICULARLY TRUE WHEN ATTEMPTING TO OBTAIN ELECTRIC OR MAGNETIC FIELD STRENGTH MEASUREMENTS IN CONFINED QUARTERS, FOR EXAMPLE INSIDE CABINETS CONTAINING ELECTRICALLY OPERATED EQUIPMENT, ELECTRIC POWER SUBSTATIONS OR IN VERY CLOSE PROXIMITY TO THE CONDUCTORS OF ENERGIZED POWER LINES. ACCIDENTAL CONTACT WITH OBJECTS OR CIRCUITS OPERATED AT HIGH VOLTAGES OR HIGH CURRENTS CAN BE LETHAL! ETS-LINDGREN, INC. ASSUMES NO LIABILITY FOR DAMAGES OR PERSONAL INJURY WHICH MAY RESULT FROM ACCIDENTS ARISING OUT OF USE OF THIS EQUIPMENT.

This page intentionally left blank.

Appendix B: EC Declaration of Conformity



EC Declaration of Conformity

We, ETS-Lindgren Inc.,
1301 Arrow Point Drive, Cedar Park, Texas, 78613, USA,
declare under our sole responsibility that the product:

Product: HI-3627 Elf Magnetic Field Meter

Description: The HI-3627 ELF Magnetic Field Meter is designed to measure the flux density of magnetic fields in the frequency range of 5 Hz to 2 kHz

to which this declaration relates in conformity with the following European, harmonized and published standards at date of this declaration:

Standard(s):

EN 61326-1:2013 Electrical Equipment for Measurement, Control and Laboratory use - emc Requirements - Part 1: General Requirements

EN 61010-1: Safety Requirements for Electrical Equipment for Measurement, Control, and Laboratory Use

Directive(s):

- Low Voltage Directive (LVD): 73/23/EEC and its amending directives
- Electromagnetic Compatibility Directive (EMC): 89/336/EEC and its amending directives

Authorized Signature:

Jim Psencik
Vice President, Engineering
ETS-Lindgren Inc.

Date of Issue