

Auto-Seal™ II Door

User Manual

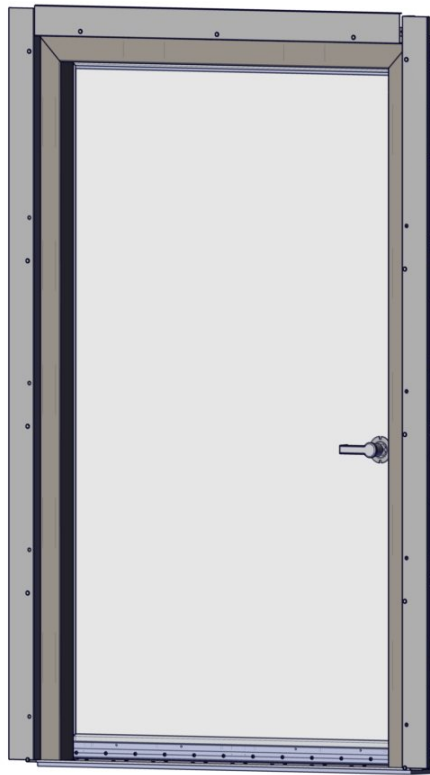

ETS-Lindgren Inc. reserves the right to make changes to any products herein to improve functioning or design. Although the information in this document has been carefully reviewed and is believed to be reliable, ETS-Lindgren does not assume any liability arising out of the application or use of any product or circuit described herein; nor does it convey any license under its patent rights nor the rights of others. All trademarks are the property of their respective owners.

© Copyright 2014–2016 by ETS-Lindgren Inc. All Rights Reserved. No part of this document may be copied by any means without written permission from ETS-Lindgren Inc.

Trademarks used in this document: The *ETS-Lindgren* logo is a registered trademark of ETS-Lindgren Inc; *Auto-Seal* is a trademark of ETS-Lindgren Inc; *3M* and *Scotch-Brite* are trademarks of 3M.

Revision Record

MANUAL,AUTO-SEAL II | Part #206376, Rev. B

Revision	Description	Date
N/A	Applied current style settings to historic document without revision record. Not tracked in Syteline or vault.	September, 2014
B	Updated to current specifications	August, 2016

Table of Contents

- Notes, Cautions, and Warningsvi**
- Safety Informationvi**
- 1.0 Introduction7**
 - Optional Items..... 7
 - Air Supply 7
 - Keypad System 7
- 2.0 Maintenance9**
 - Door System 9
 - Optional Air Compressor 9
 - Alternate Compressor..... 9
- 3.0 Operation 11**
 - System Power..... 11
 - Seal / Unseal the Door 12
 - Turn Off System Power 12
 - Lock/Unlock the Door 12
 - Customer Connections 12
- 4.0 Optional Equipment..... 15**
 - Optional Automatic Door 15
 - Optional Auto-Seal Keypad 15
 - Wiring Schematic 16
 - Operation 17
 - Customer Connections 17
 - Maintenance 17
- Appendix A: Warranty 19**

This page intentionally left blank.

Notes, Cautions, and Warnings



Note: Denotes helpful information intended to provide tips for better use of the product.



CAUTION: Denotes a hazard. Failure to follow instructions could result in minor personal injury and/or property damage. Included text gives proper procedures.



WARNING: Denotes a hazard. Failure to follow instructions could result in SEVERE personal injury and/or property damage. Included text gives proper procedures.

Safety Information



Refer to Manual: When product is marked with this symbol, see the instruction manual for additional information. If the instruction manual has been misplaced, download it from ets-lindgren.com, or contact ETS-Lindgren Customer Service.



High Voltage: Indicates presence of hazardous voltage. Unsafe practice could result in severe personal injury or death.



High Voltage: Indicates presence of hazardous voltage. Unsafe practice could result in severe personal injury or death.



Protective Earth Ground (Safety Ground): Indicates protective earth terminal. You should provide uninterruptible safety earth ground from the main power source to the product input wiring terminals, power cord, or supplied power cord set.

1.0 Introduction

The **ETS-Lindgren Auto-Seal™ II (AS-II)** is a heavy-duty, all stainless steel frame, and hollow metal door construction. For the top and two sides, the radio frequency (RF) seal is embedded in the jamb and expands toward the door by means of a pneumatically-driven mechanism. At the threshold the seal and mechanism are located on the bottom of the door. The expanded seal connects the door to the doorjamb. Doorjamb and shielded enclosure are also conductively fastened, thus effectively extending the shield across the door opening, preventing RF interference from entering or leaving the enclosure.

The electro-pneumatic method of operating the door is virtually maintenance-free. It allows operation of the door from either side. In the event of electrical or pneumatic failure the logic system automatically defaults to **Unseal** mode. The system is located inside the doorjamb. A power supply is located outside the room and supplies the door with power.

The power supply box also has other connections. That may be used to interconnect any customer indicator lamps or scan functions into the operation of the door. In addition to customer connections, there are also connections for an emergency pushbutton. See *Operations* on page 11 for more information.

The door requires an air compressor that may be included as an option or provided by the customer. The air supplied to the door must be dry and PSI regulated. 100 PSI is optimal, and 110 PSI is maximum.

Two emergency buttons are included; one located inside the room and one outside. Each will cut electrical power to the door, making it operate like a normal door.

Optional Items

AIR SUPPLY

A compressor with an auto-drain system is available upon request. See *Operations* on page 11 for more information regarding the integration of the air supply with the AS-II system. If using another compressor, it must have an auto drain system or other method of keeping the air dry.

KEYPAD SYSTEM

A keypad system is available that will allow the door to open via the keypad from the outside of the room. Use the door handle to exit the room.

This page intentionally left blank.

2.0 Maintenance



CAUTION: Before performing any maintenance, follow the information provided in *Safety Information* on page vi.

Door System



CAUTION: Do not sand the door seals.

CAUTION: Do not close the door with any obstructions across the threshold or in the door opening (power cords, etc.).

- Keep the stainless steel threshold clean and free of wax or floor polish. Make sure that the sides and top of the stainless steel door leaf are also clean.
- Use an abrasive sponge (similar to a 3M™ Scotch-Brite™ scouring pad) to clean the door and threshold where the seals make contact. The surfaces that can be sanded are the threshold, door top, and two door sides. Sand in the length direction.
- Use a clean cloth to wipe off the surfaces.



Note: For maximum performance, repeat this procedure monthly.

Optional Air Compressor

Check the level of water in the moisture collector and empty as needed. Repeat at least once a month, even though water may not reach the maximum level.

Alternate Compressor

If you supplied your own compressor, follow the manufacturer's recommended maintenance procedures.

This page intentionally left blank.

3.0 Operation



CAUTION: Before placing into operation, follow the information provided in *Safety Information* on page vi.

System Power



Note: Remove the top jamb cover to reach the door connections.

1. Connect power to the system. Make sure the power supply is plugged into a 120 or 240 VAC power outlet, and then connect power to the door using a CAT-5E cable.
 - **In-Swing Door:** A CAT-5E connection runs from the power supply to the clean side of the filter, and from the filter to the top of the door.
 - **Out-Swing Door:** The CAT-5E connection runs from the power supply to the top of the door.
2. Connect air to the system using 1/4 inch tubing.
 - **In-Swing Door:** An air fitting is on the clean side of the filter. The other side of the fitting must be connected with the air connection on top of the door.
 - **Out-Swing Door:** Connect the compressor output with the air connection on top of the door inside the jamb.
3. Make sure the air supplied is dry, and that the pressure is between a minimum of 100 PSI and a maximum of 110 PSI.

Doors that are closed into the jamb will automatically seal when system power is initiated.



Note: Connect emergency system. Door will not operate without it.

Seal / Unseal the Door

To seal the door: Swing the door to the closed position. Upon closing, a sensor activates the logic system and allows regulated pressurized air to enter the sealing system. The door will immediately seal. This process may be repeated from either side of the door.

To unseal the door: Turn the door handle and swing the door open. As the handle is turned, air pressure will exit the sealing system instantly, and the door can be opened without delay. This process can be repeated from either side of the door.

Turn Off System Power

To turn off the system, unplug the power supply. In cases where an emergency switch is installed, push the emergency switch. It will cut power to the power supply.

Pneumatic or electric doors will automatically unseal as soon as power is turned off.

Lock/Unlock the Door

A classroom-type handle is used on each door and includes a lock. If the door is locked, no one can enter the room without the key; however, a person in the room may exit without the use of a key. Use the key provided to lock or unlock the door.

Without a power supply, the door defaults to a regular door. If it is locked, a key is required for entry.

Emergency buttons are to be installed inside the MRI room and the control room.

Customer Connections

The customer connections are located on the power supply.

Two sets of dry connections are available. Set 1 has a **COM**, **NC**, and **NO** connection; Set 2 has similar connections.

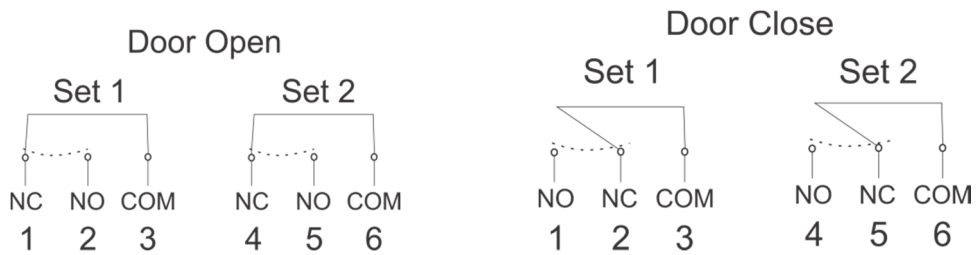
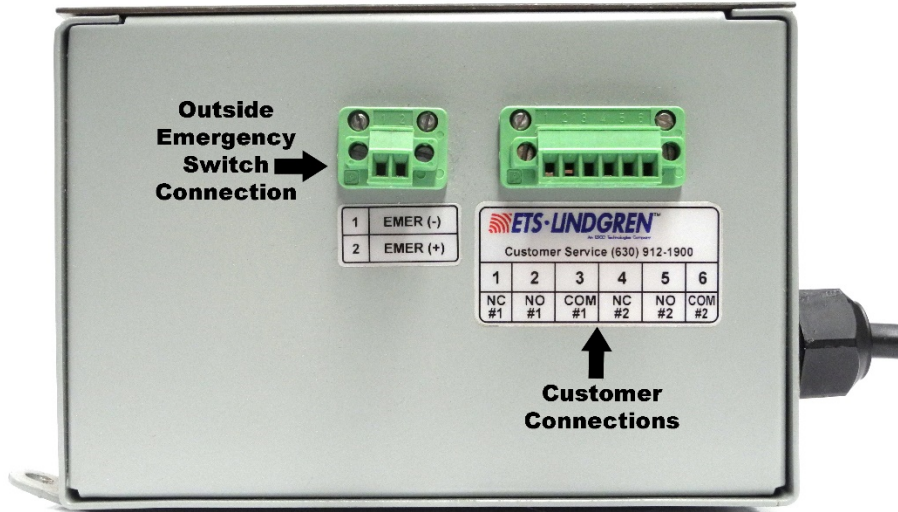

Next to the customer connections is the connection for an emergency switch. If an emergency switch is desired, remove the jumper and connect the emergency switch.

This page intentionally left blank.

4.0 Optional Equipment



CAUTION: Before placing into operation, follow the information provided in *Safety Information* on page vi.

Optional Automatic Door

- Standard push pads on inside and outside of the room with a keyed switch by the control room for safety lock out.
- Optional keypad control on outside of room with a push pad on inside of room.
- Customer-provided card reader can be configured to control door from outside.
- Optional Safe IV Port (SIVP) on AS-II door allows IV lines to be run through the jamb area to inside the room without being disconnected.

Optional Auto-Seal Keypad

An Auto-Seal™ II keypad door is a standard door with the addition of a keypad. A door with a keypad system has several differences from a standard door.

- Uses a keypad to open the door from the outside and a handle to open from the inside.
- A power supply box is supplied with the door; it should be located at the equipment room.
- Connect air to the compressor first, and then to the door.
- If more wiring is needed than for standard doors, see wiring schematic for wiring details.



Note: Do not install emergency buttons near the keypad outside the room.

WIRING SCHEMATIC

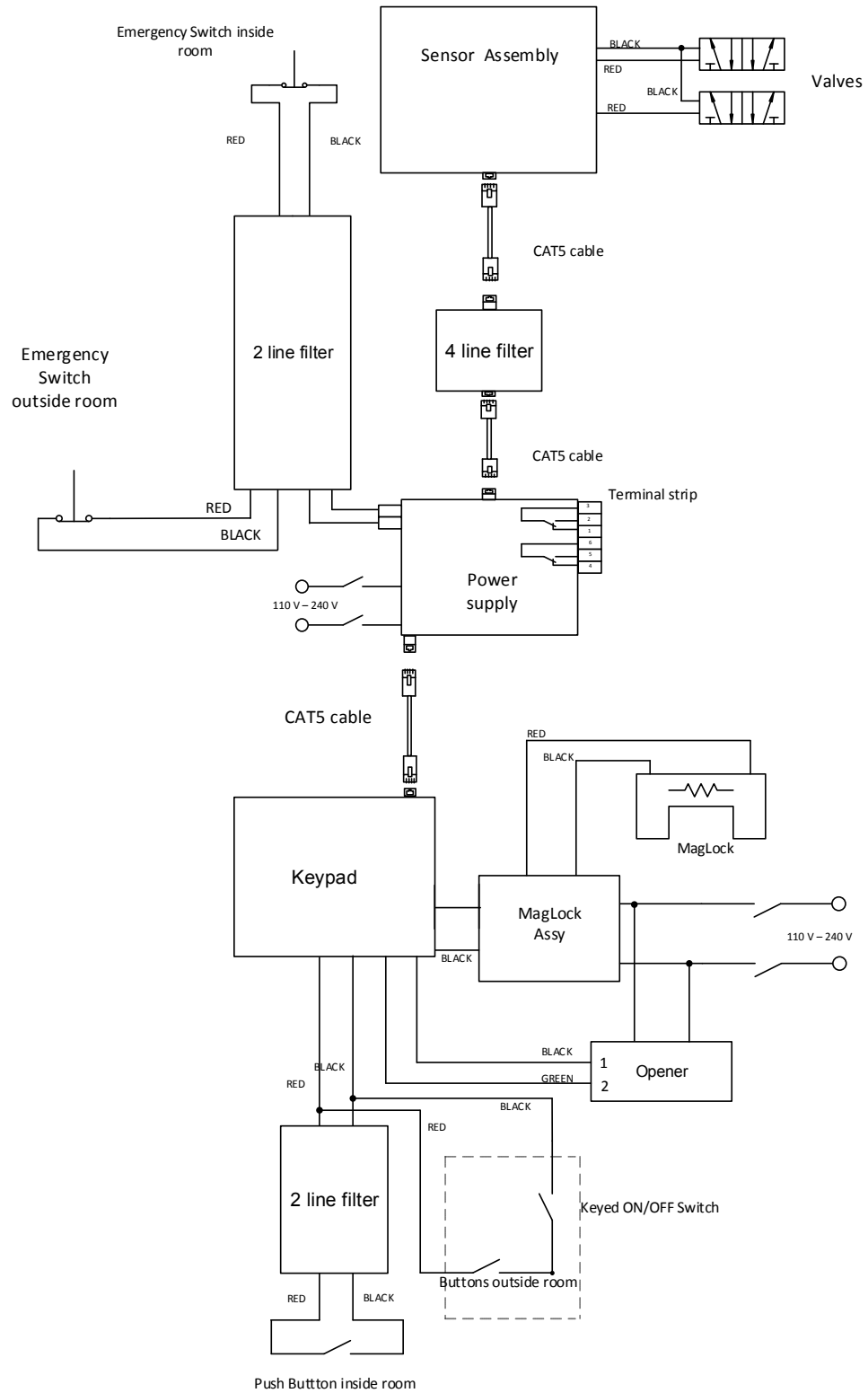

Operation

To enter the room:

1. Type the code on the keypad
2. Turn the handle to open the door.
3. There is a window of 10 seconds for the user to turn the handle. If the handle is not turned during those 10 seconds, the door will seal again.
4. In case of an emergency, push the red button located in the control room to unseal the door. The emergency button will cut electrical power to the control system, causing the door to operate like a standard door (seals do not operate). To reset the emergency button, turn it clockwise.

To exit the room:

1. Turn the handle to open the door.
2. In case of an emergency, push the red button to unseal the door. The emergency button will cut electrical power to the control system, causing the door to operate like a regular door (seals do not operate). To reset the emergency button, turn it clockwise.

Customer Connections

A dry contact from the PLC is allocated for customer usage. Two purple wires are connected to the contact and are brought out of the control box in a steel connection box. The contact is **NO** when the door is open and turns to **Closed** when the door closes.

Maintenance

Follow the maintenance procedures outline for the standard door.

This page intentionally left blank.

Appendix A: Warranty



See the *Product Information Bulletin* included with your shipment for the complete ETS-Lindgren warranty for your Auto-Seal™ II.

DURATION OF WARRANTIES FOR AUTO-SEAL™ II

All product warranties, except the warranty of title, and all remedies for warranty failures are limited to two years.

Product Warranted	Duration of Warranty Period
Auto-Seal II™ Door	1 Year