



WIRELESS SOLUTIONS

ANTENNA PATTERN MEASUREMENT (APM)
2G-5G CELLULAR PERFORMANCE
GNSS, WI-FI, BLUETOOTH, IOT

SISO AND MIMO TEST SYSTEMS
TEST SOFTWARE
COMPONENTS
SERVICES

**COMMITTED TO A SMARTER,
MORE CONNECTED FUTURE**

**ETS-LINDGREN**[®]
An ESCO Technologies Company



AN EXPERIENCED PARTNER YOU CAN TRUST.

THE EXPERT IN WIRELESS TEST AND MEASUREMENT

ETS-Lindgren is the proven expert in test and measurement solutions. Our ability to create real-life test scenarios and solutions enables customers around the globe to verify, measure, isolate, and ultimately bring life-changing products to markets – faster. Every day, when people use their cell phones, drive their cars, work on their laptops, or stream music, more than likely they are benefitting from the technological investments and innovative systems and components developed by ETS-Lindgren.

As much as we're recognized for our technology, innovation, and engineering, ETS-Lindgren is very much a people company. Around the globe we bring an understanding that the most effective solution begins with something far more basic than the products and technology we develop – a partnership between people.



ANTICIPATING THE NEEDS OF AN EVOLVING UNIVERSE



By continuously expanding our wireless, OTA, and 5G product offerings, ETS-Lindgren is always looking to provide new solutions for our customers. In this brochure, solutions that are currently part of our innovation process or in development are noted with the above icon. For availability please contact your ETS-Lindgren office or representative.

ETS-Lindgren supported the development of the industry's first Over-the-Air (OTA) measurement plan and pioneered the world's first CTIA Authorized Test Lab for mobile station OTA performance testing. Our unparalleled expertise and our full line of Solutions for the entire wireless product cycle is why ETS-Lindgren has designed and built a staggering 80 percent of the CTIA OTA labs that exist today.

Our experience uniquely qualifies ETS-Lindgren to address the emerging fifth generation (5G) and mmWave test requirements. Not only do we have the proven technical depth of an industry leader, we also have the ability to work with our customers to provide the optimal Test and Measurement Solution for their specific performance metrics, budget objectives, and/or space constraints. Since each wireless device manufacturer or carrier may have its own specific performance metrics, ETS-Lindgren offers customized Solutions to meet these individual requirements, including applications for:

- 2G/3G/4G/Wi-Fi SISO OTA
- 4G/Wi-Fi MIMO OTA
- 5G Frequency Range 1 (FR1) SISO/MIMO OTA
- 5G Frequency Range 2 (FR2) SISO/MIMO OTA
- Radiated Spurious Emissions (RSE)
- Passive Antenna Pattern Measurement (APM)

For a complete list of test applications, please see pages 8 and 9.



ETS-Lindgren is an active contributor to many of the device certification standards for the wireless industry and has first-hand knowledge of the recent changes to the over-the-air performance requirements and standards development work in 3GPP, CTIA, and Wi-Fi Alliance. Our customers can be rest assured that an ETS-Lindgren Test and Measurement Solution will prepare them for meeting current and future requirements.

CERTIFIED COMPANY
ISO 9001:2015
 CEDAR PARK • BANGALORE
 BEIJING • DURANT • EURA
 MINOCQUA • WOOD DALE



Products with this logo meet 3GPP requirements for 5G. See individual products for details.



FLEXIBLE SOLUTIONS FOR ALL YOUR TESTING NEEDS



ETS-Lindgren offers testing solutions covering the entire product cycle.

As our customers' requirements vary greatly, so do ETS-Lindgren's Testing Solutions. We offer systems and products for each point in a product testing cycle as well as the flexibility to choose from several scan methods (see pages 6 and 7 for more information).

To assist you in your testing requirements, ETS-Lindgren provides standard and custom test components to meet your project needs, including:

- RF Shielding, Shielded Test Enclosures, and Shielded Doors
- RF Absorber
- Measurement and Reference Antennas
- Reflectors
- Hand, Head, and Device Under Test (DUT) Mounts

For information on ETS-Lindgren wireless components, please see pages 44 and 45, visit our website at www.ets-lindgren.com, or contact your local ETS-Lindgren representative.

In addition to our products, ETS-Lindgren employs experts qualified to perform a wide range of Services, including:

- Engineering and Design
- Calibration and Repairs
- Field Services
- In-House Testing
- ETS-U Educational Programs

For information on ETS-Lindgren Services, please see pages 46 and 47, visit our website, or contact your local ETS-Lindgren representative.

A photograph of an anechoic chamber, a specialized facility used for testing electromagnetic waves. The chamber's interior is lined with numerous dark, pointed pyramidal absorbers designed to eliminate reflections. In the center, a testing setup is visible, featuring a white base with several vertical probes or antennas. The lighting is dramatic, with bright spots reflecting off the metallic surfaces of the absorbers.

ETS-Lindgren recognizes that every project has specific requirements. Because of this, we offer multiple types of scanning methods for 5G, OTA, APM, MIMO and SISO testing. If you are unsure which scanning method is suitable for your project, let the experts at ETS-Lindgren assist you in selecting the best method for your testing needs.

MORE SCANNING SOLUTIONS THAN ANYONE ELSE

ETS-Lindgren offers the following types of scanning for wireless systems:

- Combined-Axis
- Theta-Arm Distributed-Axis
- Theta-ARC or Single Antenna ARC Distributed-Axis
- Multi-Antenna Distributed-Axis
- Reverberation Distributed-Axis

Please see the following page for illustrations of these scanning methods.

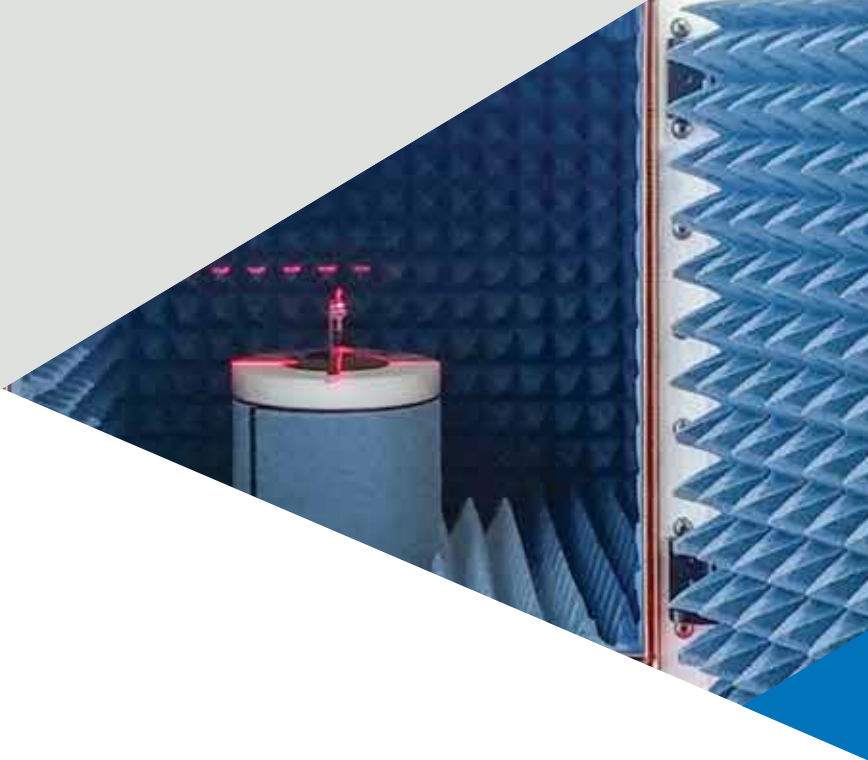

SCANNING METHODS

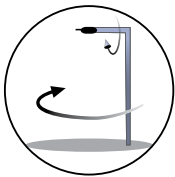

Combined-Axis Scanning Method



Multi-Antenna Distributed-Axis Scanning Method
Shown with Optional Goniometer



Combined-Axis Scanning Method
Shown with Optional Phantom Head

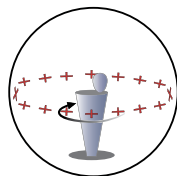

Multi-Antenna Distributed-Axis Scanning Method

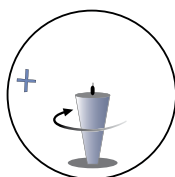

Azimuth Axis Scanning Method

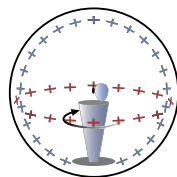

Multi-Antenna Dual-Ring Distributed-Axis Scanning Method
Shown with Optional Dual Ring

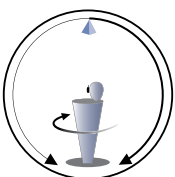

Theta-Arm Distributed or Fixed ARC Axis Scanning Method

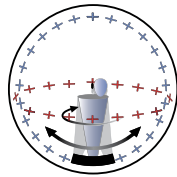

Multi-Antenna Dual-Ring Distributed-Axis Scanning Method
Shown with Optional Dual Ring and Optional Goniometer



Multi-Antenna Distributed-Axis Scanning Method

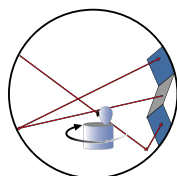

Reverberation Distributed-Axis Scanning Method

WIRELESS SOLUTIONS SELECTOR

	AMS-7000	AMS-7200	AMS-8040	AMS-8041	AMS-8042	AMS-8050	AMS-8100	AMS-8500	AMS-8700
<i>Page Number</i>	20	21	22	23	24	25	26	27	28
5G NR FR1 SISO	X	X	X	X		X	X	X	X
5G NR FR2 SISO									
5G NR FR2 MIMO									
2G/3G/4G SISO	X	X	X	X		X	X	X	X
Wi-Fi SISO	X	X	X	X		X	X	X	X
4G/FR1/Wi-Fi MIMO	X	X							X
FR2 MIMO									
FR1 Carrier Aggregation	X	X	X	X		X	X	X	X
GNSS			X	X		X	X	X	X
WiGig									
Bluetooth	X	X	X	X		X	X	X	X
IoT	X	X	X	X		X	X	X	X
RSE	X	X	X	X		X	X	X	X
Automotive Radar					X				
Passive Antenna Pattern			X	X		X	X	X	X



AMS-8800	AMS-8900	AMS-5700	AMS-5701	AMS-5702	AMS-5703	AMS-5704	AMS-5705	AMS-5706	AMS-5707 ¹	AMS-5708 ¹	AMS-5709
29	30	34	35	36	37	38	39	40	41	42	43
X	X				X				X	X	
		X	X	X	X		X	X	X	X	X
											X
X	X										
X	X										
	X										
											X
X	X										
X	X										
						X					
X	X										
X	X										
X	X	X	X	X	X	X	X	X	X	X	X
							X				
X	X	X	X	X	X	X	X	X	X	X	X

¹ Product Roadmap item. Test Solution currently in development.

OTA, APM, MIMO, AND SISO SOLUTIONS

ETS-Lindgren is the world leader for Over-The-Air (OTA) Performance Testing of Wireless Subscriber Devices and in the development of significant intellectual property in wireless OTA measurement. Our long history in wireless testing includes development of the industry's first OTA measurement plan, the world's first CTIA Authorized Test Lab (CATL) for mobile station OTA performance testing, many patents, and numerous awards. With our unparalleled expertise and our full line of innovative Solutions from design to certification level testing, ETS-Lindgren has provided the vast majority of CTIA OTA labs in use today – globally.

For Antenna Pattern Measurement (APM) Solutions, ETS-Lindgren provides expertise from design to fabrication to installation, ensuring that your customized Solution will meet your specific requirements, including the integration of a wide variety of services and components to complement your APM needs.



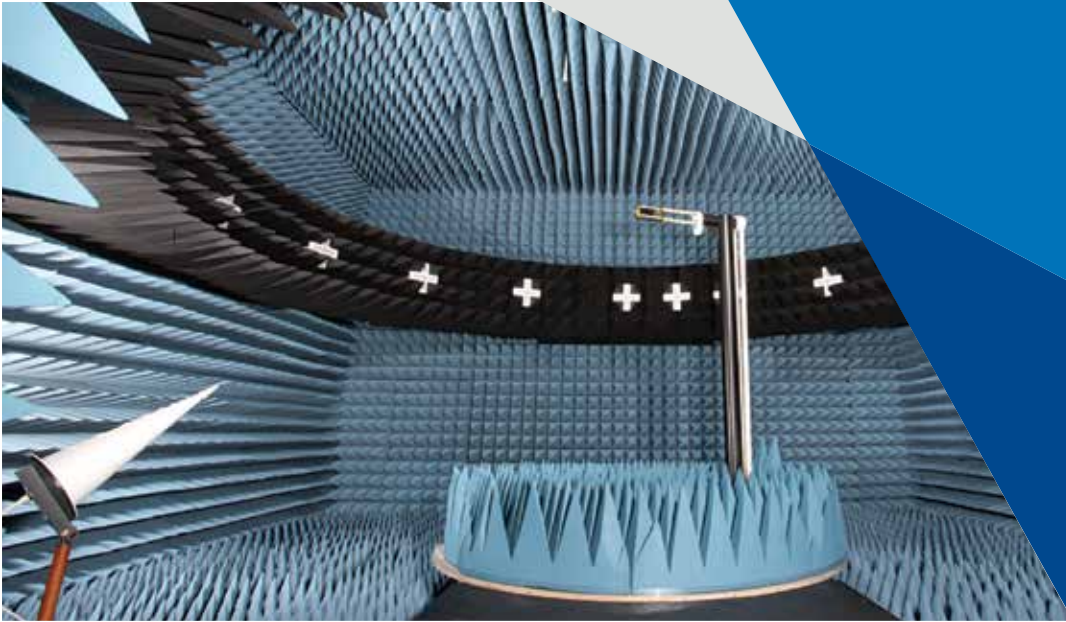

OTA, APM, MIMO, AND SISO SOLUTIONS: TEST SYSTEMS

STANDARD SYSTEM SOLUTIONS

Wireless carriers have standardized several test metrics to ensure devices will perform well on the network. ETS-Lindgren is the hands-down leader of this market with the AMS-8000 series of OTA chambers. In this model lineup you will find a Test Solution for nearly any radio technology, antenna configuration, DUT size, scan method, and range length. Each AMS-8000 series model has a specialty: passive or active pattern measurements, SISO, MIMO, channel model application, or radio desense tests. Radio technology packages can be added to most AMS-8000 models, supporting the simplest Bluetooth audio device to the most complex smart phone with multiple radios.

Our global lead in OTA testing is about more than just great chambers: project management, installation, and user training are as important as the hardware itself. Leadership in each of these metrics has been earned from thousands of installations around the globe.

CUSTOM SYSTEM SOLUTIONS

Several FR1 Standard Test Solutions are detailed in the following pages, but customization is our specialty, with proven technical depth, project management, and partnerships to execute the most complex measurement systems. ETS-Lindgren is renowned worldwide for executing the toughest projects in the wireless industry, so bring us your ideas if the Standard Solutions do not quite fit your requirements.

For more information on our Custom Design Capabilities, please contact your local ETS-Lindgren representative.

OTA, APM, MIMO, AND SISO SOLUTIONS: PORTABLE TEST ENCLOSURES

7000 AND 8000 SERIES PORTABLE TEST ENCLOSURES

In addition to wireless test chambers, ETS-Lindgren also offers numerous portable RF Shielded Test Enclosures. Each Test Enclosure offers the same rigorous design as our full-sized chambers with the added flexibility of resource sharing between labs. Additional features include frequency range, physical format (tabletop, wheeled enclosures), and rotation axis.





5G FR1 SOLUTION

5G FR1 testing utilizes the same methods and environments as did LTE, so our industry leading CTIA certified chambers found around the world need only be augmented with an upgrade package to support 5G. Both non-standalone (NSA) and stand-alone (SA) modes are supported, as are EN-DC plus a wide array of carrier aggregation scenarios. EMQuest™ Antenna Pattern Measurement Software continues to support all major brand test equipment. Instrumentation vendors are adding both simplified models and pushing advanced capabilities into the flagship units. As 5G Advanced, 6G, and Wi-Fi 7 keep the best-in-class instrument title up for grabs, only ETS-Lindgren gives you the flexibility to shift instrumentation as the market diversifies.

For more information, visit our website or contact your local ETS-Lindgren representative.



5G mmWAVE SOLUTIONS

OTA test techniques were developed to address situations where the radio, antenna, and embedded platform must be evaluated as a system rather than as isolated components. 5G wireless network's use of active antenna systems (AAS) has greatly increased the battery of tests that must now be done within an OTA environment. 4G and 5G base stations and all 5G FR2-capable devices utilize beam steering array antenna systems where overall radio performance cannot be disassociated from the antenna performance. Transmitter conformance and production line tests that are normally performed with a direct cable connection have also shifted to be OTA tests on FR2-capable devices. Even electromagnetic compatibility (EMC) testing is impacted by active antenna systems, where spurs and harmonics require diligent searching for signal peaks. mmWave OTA systems are generally separate chambers from those that support LTE and FR1 because the high frequency of transmission requires several system-wide adaptations.

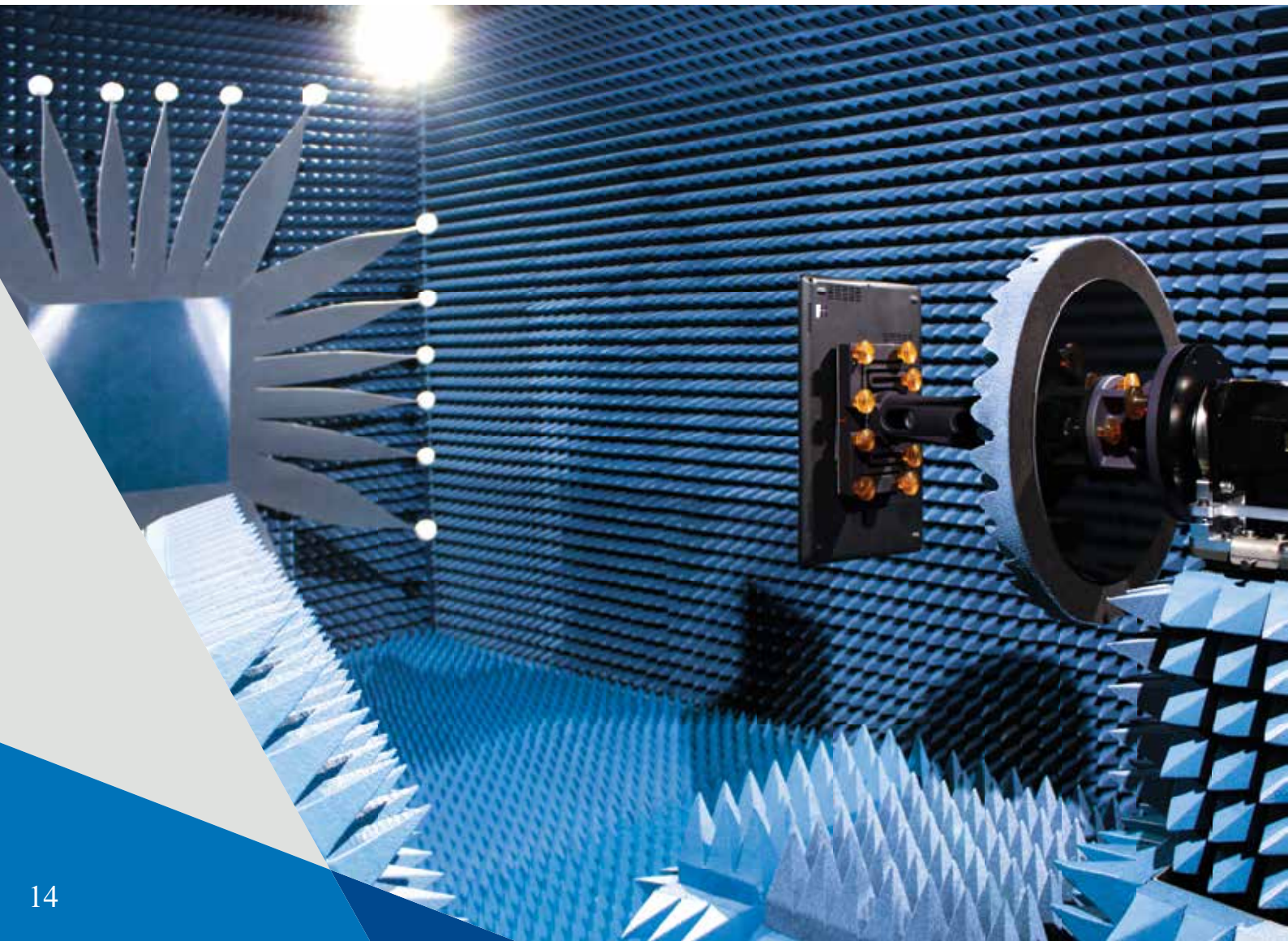



5G mmWAVE SOLUTIONS: TEST SYSTEMS

STANDARD SYSTEM SOLUTIONS

The AMS-5700 series supports mmWave active and passive antenna pattern measurements. The models in this series cover a vast spectrum of quiet-zone sizes, frequency ranges, and scanning methods. Large quiet zones are accomplished by utilizing a compact antenna test range (CATR) design using a wave-shaping reflector. Combined-axis designs that move the device under test (DUT) in azimuth and elevation provide highly flexible measurement antenna options, such as variable range length and easy swapping of the antenna to cover wide frequency ranges. Bulky and heavy devices can be best handled by distributed-axis systems where the DUT must only be azimuth-rotated while the measurement antenna moves to scan the elevation axis. ETS-Lindgren provides several models in this series, each optimized to cover particular test variables.

Military, radar, and satellite communications drove the initial development of mmWave test systems, but 5G has exploded the interest in testing at higher frequencies. 5G FR2 covers roughly 24 to 44 GHz and 6G researchers plan to utilize various bands into the hundreds of GHz. The AMS-5700 model line supports antenna testing for both data-consumer and server-side equipment: smart phones to gNBs and everything in between. Most AMS-5700 models meet SISO quiet-zone requirements set by CTIA, 3GPP, FCC, CCC, and other regulators. FR2 MIMO measurements are still being specified, but ETS-Lindgren representation on 3GPP and CTIA standards committees ensures the AMS-5709 will meet the requirements when issued.

CUSTOM SYSTEM SOLUTIONS

While the AMS-5700 models cover a high percentage of 5G test requirements, custom systems are a specialty of ETS-Lindgren. Our engineers love a challenge, so if our existing models don't quite cover your requirements, we excel at creating Custom Solutions and adaptations that will.

For more information on our Custom Design Capabilities, please contact your local ETS-Lindgren representative.



5G mmWAVE SOLUTIONS: PORTABLE TEST ENCLOSURES

5700 SERIES PORTABLE TEST ENCLOSURES

In addition to full-sized chambers, the 5700 series also includes several portable test enclosures designed specifically for 5G testing in the mmWave spectrum (3GPP FR2). There are different test solutions available for 2D and 3D testing, depending upon the test requirement. These Solutions can characterize the performance of the radio against the 3GPP FR2 test specifications where the antenna pattern is locked into a static mode. Traditional Antenna Under Test (AUT) manipulation techniques are used to obtain the required test parameters from the resulting pattern. Other model-specific features include frequency range, physical format (tabletop, movable enclosures), and rotation axis.

5700 Series portable test models include:

- AMS-5700
- AMS-5701
- AMS-5702
- AMS-5704
- AMS-5705
- AMS-5706
- AMS-5709



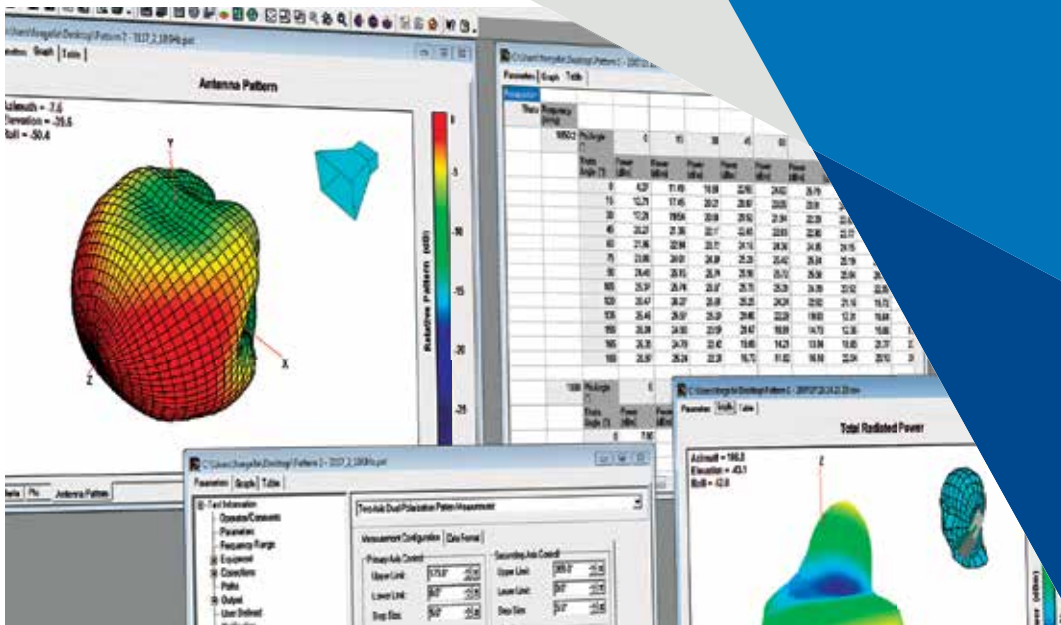

TEST SOLUTIONS: SOFTWARE

EMQUEST EMQ-100 ANTENNA MEASUREMENT SOFTWARE

ETS-Lindgren's EMQuest EMQ-100 Antenna Measurement Software offers a wide range of fully parameterized test methods for measuring basic antenna performance metrics, as well as testing both radiated and conducted performance of various wireless devices. Whether you're designing antennas for stand-alone applications, or testing an embedded antenna system and radio module against any of the industry standard OTA radiated performance test requirements, EMQuest EMQ-100 provides the flexibility to meet your testing needs. Using appropriate wireless communication testers and power measurement devices from an extensive listing of optional test equipment drivers, OTA performance can be evaluated for a broad range of wireless technologies. Additionally, EMQuest supports all major brands of test equipment.

EMQUEST EMQ-118 EXECUTIVE DATABASE OPTION

EMQuest EMQ-118 can boost productivity by providing the ability to export and store data results in a relational database, such as PostgreSQL or Microsoft SQL servers. The Software's inherent flexibility includes SQL DDL commands to create the tables for either of these databases. Additional tools are provided to select and pull the data back out for further analysis.

The EMQuest database system further benefits the user by allowing customer-created queries written in the customer's choice of language, such as Python or Microsoft Excel. The data can be automatically inserted into the database if EMQuest-118 is used to run the EMQuest test, or results can easily be dragged and dropped into EMQuest-118 manually. EMQ-118 provides simple data extractions and report creation, though the standard EMQuest viewer can still be utilized to extract the raw data files (RAWX2 format), which can then be loaded and analyzed by EMQuest.

AT A GLANCE: OTA, APM, MIMO, AND SISO TEST SYSTEMS

	AMS-7000	AMS-7200	AMS-8040	AMS-8041
Target/Optimum Application	Wireless Device Performance Validation (TRP/TIS and MIMO Performance Measurements)	Wireless Device Performance Validation (TRP/TIS and MIMO Performance Measurements)	R&D, Manufacturing QA, Receiver/Transmitter Calibration, Fixed Beam Applications, Regression Testing (TRP,EIRP, EIS, TIS)	R&D, Manufacturing QA, Receiver/Transmitter Calibration, Fixed Beam Applications, Regression Testing (TRP,EIRP, EIS, TIS)
Description	Azimuth Axis Rotation Scanning Method	Azimuth Axis Rotation Scanning Method	Combined-Axis Scanning Method	Combined-Axis Scanning Method
Typical Test Device Type	Phone, Tablet, Laptop	Phone, Tablet, Laptop, Large M2M	Phone	Phone, Small Tablet
Compliance Standard/Technology	3GPP	3GPP	Pre-Compliance	Pre-Compliance
Frequency Range	690 MHz to 6 GHz	200 MHz to 6 GHz	400 MHz to 6 GHz	400 MHz to 6 GHz
Testing Methodology	Reverberation Chamber	Reverberation Chamber	Direct Far-Field (DFF)	Direct Far-Field (DFF)
Rotation Axis	Azimuth Axis	Azimuth Axis	Combined-Axis	Combined-Axis
Path Length	N/A	N/A	95 cm (37.4 in)	80 cm (31.5 in)
Exterior Chamber Nominal Size	2.1 m x 1.6 m x 2.0 m (7.0 ft x 5.1 ft x 6.7 ft)	4.8 m x 3.6 m x 3.1 m (15.8 ft x 11.8 ft x 10.0 ft)	0.8 m x 0.9 m x 2.0 m (2.5 ft x 2.9 ft x 6.4 ft)	0.9 m x 1.0 m x 2.0 m (2.9 ft x 3.2 ft x 6.6 ft)

The AMS-7000 Portable Antenna Measurement System incorporates the reliability of a SMART reverberation chamber with the flexibility of a moveable configuration.



AMS-8042	AMS-8050	AMS-8100	AMS-8500	AMS-8700	AMS-8800	AMS-8900
R&D, Vehicle RADAR Module Antenna Performance, Object Detection Performance Analysis	R&D, Manufacturing QA, Receiver/Transmitter Calibration, Fixed-Beam Applications, Regression Testing (TRP, EIRP, EIS, TIS, RSE)	R&D, Conformance and Performance Testing (EIRP, TRP, EIS, TIS), Passive or Active Antenna Testing	R&D, Conformance and Performance Testing (EIRP, TRP, EIS, TIS), Passive or Active Antenna Testing	MIMO Performance, Multi-Path, Transmit Diversity, Channel Model, AoA, Doppler, Delay Spread	Conformance and Performance Testing (EIRP, TRP, EIS, TIS), Radio Interoperability	High-Speed Conformance and Performance Testing (EIRP, TRP, EIS, TIS), MIMO Performance
Single Axis, Partial Scan; Optional Multi-Axis Scanning Method	Combined-Axis Scanning Method	Azimuth Axis (Upgraded to Combined-Axis) Scanning Method	Combined-Axis Scanning Method	Combined-Axis Scanning Method	Distributed-Axis Scanning Method	Multi-Antenna Array (Ring) Scanning Method
Automotive RADAR Module	Phone, Tablet, Laptop	Phone, Tablet, Small Cells, CPE, Laptop	Phone, Tablet, Small Cells, CPE, Laptop	Phone, Tablet, Small Cells, CPE, Laptop	Heavy Devices, Small Cells, CPE, Laptop, Base Station	Phone, Tablet, Small Cells, CPE, Laptop
ETSI 301-303 Series	Pre-Compliance	CTIA	CTIA	CTIA/MIMO	CTIA	CTIA/MIMO
24 GHz to 81 GHz	700 MHz to 10 GHz	690 MHz to 10 GHz	400 MHz to 10 GHz	600 MHz to 6 GHz 400 MHz to 6 GHz	400 MHz to 10 GHz	600 MHz to 6 GHz 400 MHz to 7.2 GHz 500 MHz to 10 GHz
Direct Far-Field (DFF) and Simulated Far-Field (SFF) (with optional target simulator)	Direct Far-Field (DFF)	Direct Far-Field (DFF)	Direct Far-Field (DFF)	Horizontal Ring of Antennas	Theta-Arm with Antenna	Theta Array with Multiple Antennas
Single Azimuth Axis Optional Combined-Axis	Combined-Axis	Combined-Axis	Combined-Axis	Combined-Axis	Single-Axis Turntable with Theta-Arm (Spherical)	Single-Axis Turntable with Multi-Antenna Ring(s)
1 m Direct Up to 200 m Simulated	1.5 m (4.9 ft)	2.75 m (9.0 ft)	4.9 m (16.1 ft)	1.95 m (6.4 ft)	1.3 m (4.3 ft) 1.5 m (4.9 ft)	Nominal 0.8 m (31.5 in) 1.5 m (4.9 ft) 1.95 m (6.4 ft) 3.2 m (10.5 ft)
1.0 m x 0.9 m x 2.2 m (3.3 ft x 2.9 ft x 7.1 ft)	2.6 m x 1.3 m x 2.0 m (8.4 ft x 4.4 ft x 6.1 ft)	4.3 m x 2.6 m x 2.6 m (14.1 ft x 8.6 ft x 8.6 ft)	7.3 m x 3.7 m x 3.7 m (24.0 ft x 12.0 ft x 12.0 ft)	4.9 m x 4.9 m x 3.0 m (16.0 ft x 16.0 ft x 10.0 ft)	4.0 m cube or 4.9 m cube (13.0 ft or 16.0 ft cube)	See Website, Varies by Pathlength Selection



The AMS-8900 Series has multiple configurations including single- and dual-antenna arrays.

WIRELESS OTA TEST SYSTEMS

AMS-7000 PORTABLE ANTENNA MEASUREMENT SYSTEM

Measurement frequency range: 690 MHz to 6 GHz

A compact reverb enclosure for antenna measurements

AMS-7000 is a Wireless OTA Reverb Antenna Measurement System designed to perform accurate and repeatable SISO and MIMO TRP and TIS measurements. The system is based on the company's long-standing line of SMART™ reverberation chambers and proven EMQuest Antenna Measurement Software.

The AMS-7000 uses two z-fold tuners, a DUT turntable, and a measurement antenna turret to improve isotropicity and homogeneity. These features allow the system to make measurements at different speeds and levels of accuracy. The reverb chamber method is accepted by some carriers for verifying TRP and TIS device performance, and is a fast, accurate, and repeatable alternative to the well-established anechoic chamber method. While the reverberation method cannot provide traditional antenna pattern information, results for TRP and TIS measurements in the AMS-7000 correlate to the ranges shown in the Measurement Accuracy table.



5G *5G-capable with FR1 upgrade available.*
Contact your ETS-Lindgren representative for details.

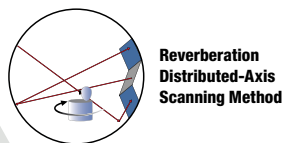

Measurement Accuracy (stir)

	Highest Accuracy	Faster Testing
TRP	0.3 dB SD	0.5 dB SD
TIS	0.3 dB SD	0.5 dB SD
Repeatability	0.2 dB SD	0.3 dB SD

Typical TRP Test Times (in minutes, per frequency)

Test Configuration	4G
Stepped	1:30
Stirred	0:30

Typical TIS Test Times (in minutes, per frequency)

Test Configuration	4G
Stepped	10:00
Stirred	3:00

AMS-7200 ANTENNA MEASUREMENT SYSTEM

Measurement frequency range: 200 MHz to 6 GHz

A space-maximizing reverb chamber designed for multiple types of wireless antenna measurements

ETS-Lindgren's AMS-7200 Reverb Antenna Measurement System is a fixed-installation reverb chamber primarily designed to meet the need for OTA testing of large-form factor devices. It supports the full range of SISO TRP, TIS, and throughput measurements for devices as small as cell phones and as large as dual-rack systems.

The chamber is equipped with dual z-fold tuner design and an independent continuous rotation turntable which, when combined with the EMQuest user-defined sampling sequence, improves the overall stirring efficiency. Additionally, the AMS-7200 features a large, easily accessible low profile turntable.

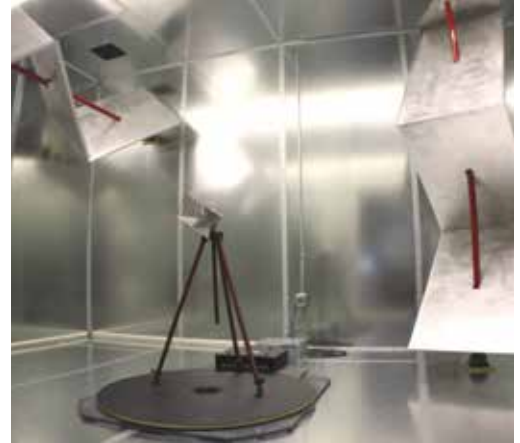

5G *5G-capable with FR1 upgrade available.*
Contact your ETS-Lindgren representative for details.

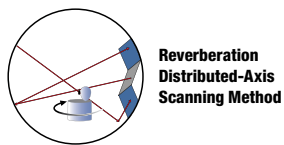

Measurement Accuracy (stir)

	Highest Accuracy	Faster Testing
TRP	0.3 dB SD	0.5 dB SD
TIS	0.3 dB SD	0.5 dB SD
Repeatability	0.2 dB SD	0.3 dB SD

Typical TRP Test Times (in minutes, per frequency)

Test Configuration	4G
Stepped	1:30
Stirred	0:30

Typical TIS Test Times (in minutes, per frequency)

Test Configuration	4G
Stepped	10:00
Stirred	3:00

AMS-8040 PORTABLE, COMPACT ANTENNA MEASUREMENT SYSTEM

Measurement frequency range: 400 MHz to 6 GHz

Fully anechoic RF test enclosure featuring an integrated 3D positioner for active testing

ETS-Lindgren's AMS-8040 Antenna Measurement System is a self-contained enclosure for performing OTA testing of wireless devices in free space. This system minimizes floor space requirements with an upright design and is ideal for battery-operated wireless devices. Measurements supported include pre-certification, design verification, production sample, desensitization, and regression testing.

It can also be used to measure approximate EIRP, EIS, or RSSI in a given direction and polarization. These results can be used to compare the behavior of multiple identical devices, or the same device under different conditions, such as external interference or desense resulting to other platform components or radios.



5G *5G-capable with FR1 upgrade available.*
Contact your ETS-Lindgren representative for details.

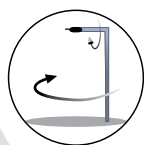

Combined-Axis Scanning Method

Typical TRP Test Times (in minutes, per frequency)

Test Configuration	4G	5G (FR1)
Stepped	<6 min	<6 min
Spiral	<2 min	<2 min

AMS-8041 PORTABLE, COMPACT ANTENNA MEASUREMENT SYSTEM

Measurement frequency range: 400 MHz to 6 GHz

Fully anechoic RF test enclosure featuring an integrated 3D positioner for passive and active testing

The AMS-8041 Antenna Measurement System is a self-contained enclosure for evaluating wireless device OTA performance. Similar to the AMS-8040 in size, the AMS-8041 adds an RF path to the DUT that provides for passive antenna-pattern testing in addition to active OTA measurements. The unit is ideal for design verification, pre-certification, production sample, desense, and regression testing.

The system is an ideal solution when space is a limitation, as it is a self-contained, freestanding test chamber. Its portable chassis makes it an excellent choice for multiple research and development groups since it is designed to fit through a typical 0.9 m x 2.1 m (3 ft x 7 ft) personnel door and can easily be moved from one test group to another.

It can also be used to measure approximate EIRP, EIS, or RSSI in a given direction and polarization. These results can be used to compare the behavior of multiple identical devices, or the same device under different conditions, such as external interference or desense due to other platform components or radios.

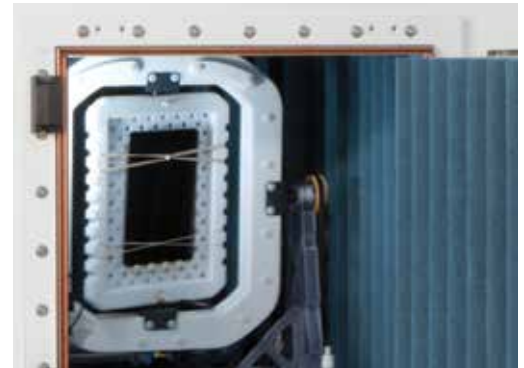

5G *5G-capable with FR1 upgrade available.*
Contact your ETS-Lindgren representative for details.

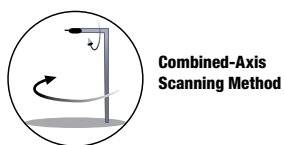

Typical TRP Test Times (in minutes, per frequency)

Test Configuration	4G	5G (FR1)
Stepped	<6 min	<6 min
Spiral	<2 min	<2 min

AMS-8042 RADAR TRANSCIVER MEASUREMENT SYSTEM

Measurement frequency range: 10 GHz to 81 GHz

A self-contained enclosure for performing evaluation and antenna measurement of RADAR modules

The AMS-8042 Antenna Measurement System supports short-range length OTA testing of automotive RADAR modules and other wireless and mmWave components in a production or R&D environment. It is ideal for device measurements, including pre-certification, design verification, production sample, and antenna-pattern testing.

With the selection of a RADAR Target Simulator (RTS), the performance of RADAR modules can be evaluated under a number of different simulated target conditions. These results can be used to compare the behavior of multiple identical devices or the same device under different conditions, such as external interference or desensitization due to the presence of noise or other interfering sources. This customizable system supports different target simulator or VNA options set up to perform automated measurements.

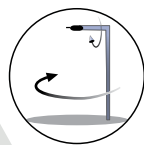
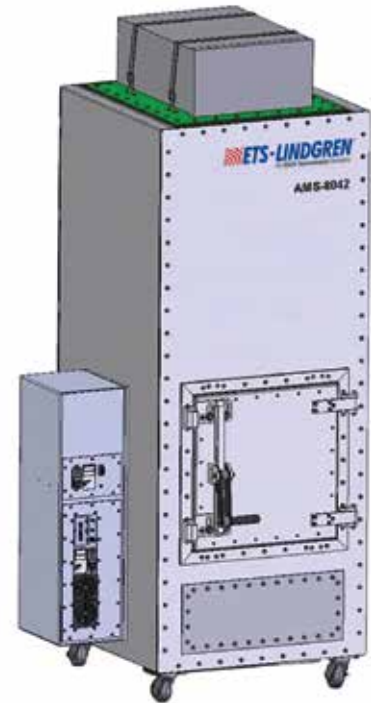

Combined-Axis Scanning Method

Example of Target Simulation Features¹

RF Range	
Frequency Range	76 GHz to 81 GHz
Spiral Optimized	76 GHz to 77 GHz (1 GHz)
	77 GHz to 81 GHz (4 GHz)

Input Power	
Max. Input Power (at RF Flange)	0 dBm
Min. Input Power (at RF Flange)	-65 dBm
Recommended Input Power (at RF Flange)	-20 dBm

Target Distance Simulator	
Min. Physical Distance, RTS to DUT	1 m
Min. Simulated Target Distance	1 m (Physical) + 3 m (Simulated)
Max. Simulated Target Distance	300 m
Distance Simulation Resolution	0.1 m
Distance Simulation Accuracy	+/- 0.3 m

Radar Cross Section Simulation (RCS) and Other RF Performance Specifications	
RCS @ -20 dBm Input Power with 25 dBi Antenna	4 m: -32 dBsm to 29 dBsm (Typical)
	300 m: 43 dBsm to 104 dBsm (Typical)
Spurious Emission	-35 dBc
Phase Noise	-90 dBc/Hz @ 10 kHz

Optional Target Speed Simulation	
Doppler Simulation Range	-360 km/h to 360 km/h
Doppler Simulation Resolution	0.1 km/h
Doppler Simulation Accuracy	+/- 0.05 km/h

¹ Extract from Keysight E8708A

AMS-8050 PORTABLE ANTENNA MEASUREMENT SYSTEM

Measurement frequency range: 690 MHz to 10 GHz

A portable, fully anechoic RF enclosure for antenna measurements

ETS-Lindgren’s AMS-8050 Antenna Measurement System utilizes a freestanding reach-in cart configuration that is on casters. Its split-shell design allows a roll-in-place installation through standard doorways and hallways, as well as portability for sharing among labs and work areas. This OTA test system may be used for rapid prototyping, design validation, pre-certification testing, performance measurement, and production sampling.

If you’re using an external test lab for certification testing, this system can help you go fully prepared. OTA performance measurements made in the AMS-8050 have shown good correlation to measurements made in larger, fully compliant chambers.

This model provides an ideal solution when space is a limitation. It can be used as a self-contained test lab for making fast OTA performance measurements of small wireless devices and mobile handsets.



5G *5G-capable with FR1 upgrade available.*
Contact your ETS-Lindgren representative for details.

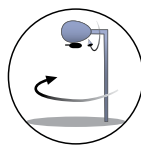

Combined-Axis Scanning Method
Shown with Optional Phantom Head

Typical TRP Test Times (in minutes, per frequency)

Test Configuration	4G	5G (FR1)
Stepped	<6 min	<6 min
Spiral	<2 min	<2 min

AMS-8100 COMPACT CHAMBER ANTENNA MEASUREMENT SYSTEM

Measurement frequency range: 690 MHz to 10 GHz

Optional Frequency: Call for Details

A compact rectangular test chamber for active and passive antenna pattern measurements

ETS-Lindgren's AMS-8100 Antenna Measurement Test Systems are designed for testing small-antenna products over the frequency range from 690 MHz to 10 GHz. This system provides active and passive testing of antennas, including those used in various devices such as Wi-Fi interfaces and mobile handsets.

AMS-8100 systems include a compact, rectangular chamber, fully lined with anechoic absorber and designed to provide far-field measurements at a nominal separation distance of 2.74 m (9 ft). The AMS-8100 can be placed in common office space thanks to its approximately 4.3 x 2.6 meter footprint and less than 3 meter (9 ft.) height clearance requirement. For 2D passive testing, a Model 2006 Single-Axis Positioning System is standard for the AMS-8100. An optional Multi-Axis Positioning System (MAPS) can be ordered for DUT rotation around two orthogonal axes for full spherical coverage.

AMS-8100 systems also include an ETS-Lindgren 3164-08 open-boundary quad-ridged horn antenna and associated RF cabling. Extension to higher frequencies is possible by adding optional antennas. Extension of the lower frequency range is possible using other ETS-Lindgren antenna measurement systems and configurations.



5G 5G-capable with FR1 upgrade available.
Contact your ETS-Lindgren representative for details.

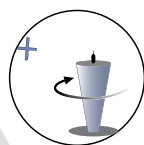

Azimuth Axis Scanning Method



Combined-Axis Scanning Method
Shown with Optional Phantom Head

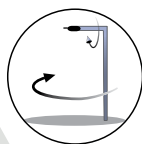

Combined-Axis Scanning Method
(Available as Upgrade)

Typical TRP Test Times (in minutes, per frequency)

Test Configuration	4G	5G (FR1)
Stepped	<6 min	<6 min
Spiral	<2 min	<2 min

AMS-8500 MULTI-AXIS ANTENNA MEASUREMENT SYSTEM

Measurement frequency range: 690 MHz to 10 GHz

Large working volume, CTIA and 3GPP certified chambers covering all FR1 frequency requirements

ETS-Lindgren's AMS-8500 Antenna Measurement Test Systems are configured to perform both research and development and type approval tests according to the CTIA Test Plan for Wireless Device Over-the-Air Performance for Radiated RF Power and Receiver Performance. These systems can also be used to perform antenna measurements in near-field and far-field test distances for more generic antenna properties.

AMS-8500 systems are designed to have better-than -25 dB quiet-zone (QZ) reflectivity, with a 0.5 m QZ size. Additionally, ETS-Lindgren can produce customized chambers, designed to fit your specific requirements.

Designed to operate over the frequency range of 690 MHz to 10 GHz, the AMS-8500 includes a full-sized rectangular chamber and offers additional frequency range coverage as an option.



5G *5G-capable with FR1 upgrade available.*
Contact your ETS-Lindgren representative for details.

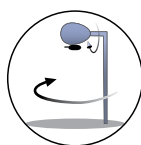

Combined-Axis Scanning Method
Shown with Optional Phantom Head

Typical TRP Test Times (in minutes, per frequency)

Test Configuration	4G	5G (FR1)
Stepped	<6 min	<6 min
Spiral	<2 min	<2 min

AMS-8700 MULTI-ANTENNA ARRAY MIMO MEASUREMENT SYSTEM

Measurement frequency range: 690 MHz to 6 GHz

Allows repeatable measurement of radiated performance of wireless devices in a simulated multi-path environment

ETS-Lindgren's AMS-8700 systems configured for the CTIA signal-to-interference test method utilize an array of either eight or sixteen dual-polarized antennas arranged to provide downlink signals from many angles of arrival at the DUT. Downlink signals are generated for each technology by a wireless network emulator and spatial channel models are applied to the RF signal fed to each antenna in the array.

AMS-8700 systems upgraded for the 3GPP power-versus-throughput test method utilize an array of sixteen antennas with each downlink RF path also containing stepping attenuators in addition to channel spatial models from the RF fader.

Automation of this test using EMQuest control software greatly reduces the complexity involved in either the CTIA or 3GPP test method.

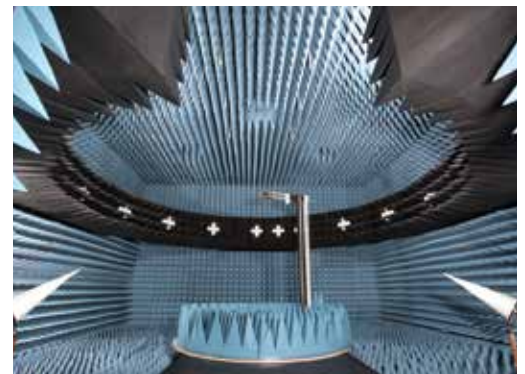

5G *5G-capable with FR1 upgrade available.*
Contact your ETS-Lindgren representative for details.



Typical MIMO Test Times (in minutes)

Test Configuration	4G	5G (FR1)
30° Stepped	<60 min	<60 min

Typical TRP Test Times (in minutes, per frequency)

Test Configuration	4G	5G (FR1)
Stepped	<6 min	<6 min
Spiral	<2 min	<2 min

AMS-8800 THETA-ARM ANTENNA MEASUREMENT SYSTEM

Measurement frequency range: 400 MHz to 10 GHz

Ideally suited for heavy or bulky antennas

ETS-Lindgren's AMS-8800 Theta-Arm Distributed-Axis Antenna-Pattern Measurement Test Systems consist of an azimuth rotator for the DUT and a separate theta-arm positioner for moving the measurement antenna around the DUT.

The theta rotational arm scanning system provides a quick, convenient, and accurate test method for wireless devices. It is a good choice for larger, heavier DUTs, especially those which may be gravity-dependent. A tabletop mount is included for testing portable computing devices, desktop computing devices, and small appliances.

The dual-polarized quad-ridged antenna on the theta-arm provides broadband measurement in both polarizations. The AMS-8800 system can be upgraded to different frequency ranges, utilizing different measurement antennas mounted on the theta-arm positioner.

The AMS-8800 series has four standard models: the AMS-8810 with a 1.0 m path length, the AMS-8812 with a 1.2 m path length, the AMS-8813 with a 1.3 m path length, and the AMS-8815, with a 1.5 m path length.

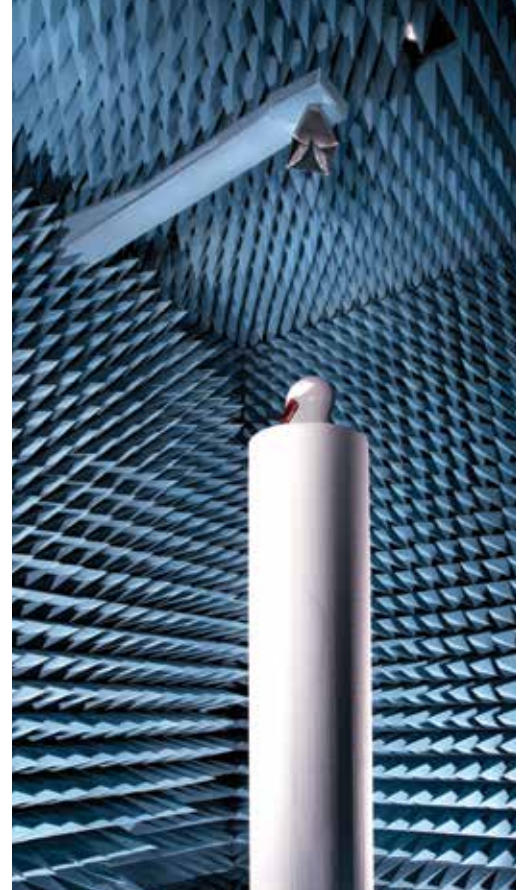

5G *5G-capable with FR1 upgrade available.*
Contact your ETS-Lindgren representative for details.



Typical TRP Test Times (in minutes, per frequency)

Test Configuration	4G	5G (FR1)
Stepped	<7 min	<7 min
Spiral	<2 min	<2 min

AMS-8900 ANTENNA PERFORMANCE SYSTEM

Measurement frequency range: 600 MHz to 6 GHz
 Optional frequencies: Down to 400 MHz and up to 10 GHz

Ideally suited for the measurement of antenna performance of wireless devices

ETS-Lindgren's AMS-8900 Multi-Antenna Distributed-Axis Test Systems are fully configured to perform both research and development and type approval measurements. These systems can also be used to perform antenna measurements in both near-field and far-field test distances for more generic antenna properties.

AMS-8900 systems include a custom multi-antenna array ring that houses a system of dual-polarized antennas. These antennas support testing between 600 MHz and 6 GHz, with an optional frequency range down to 400 MHz and up to 10 GHz. An integrated laser alignment system assists with DUT positioning.

A switch control box integrated on the ring provides fast changing between antennas for high-speed testing. Its centralized system configuration supports easy maintenance and superior reliability.

An optional goniometer is available for finer angular resolution measurements.

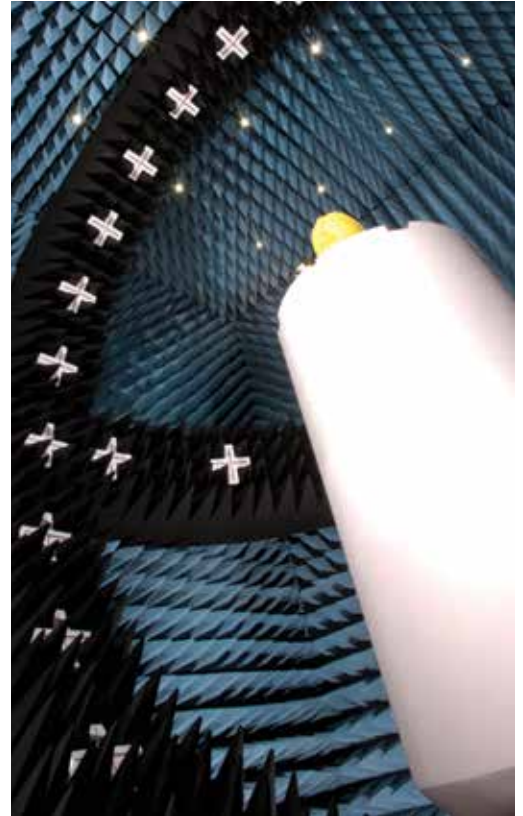

5G 5G-capable with FR1 upgrade available.
 Contact your ETS-Lindgren representative for details.



Multi-Antenna Distributed-Axis Scanning Method



Multi-Antenna Distributed-Axis Scanning Method
 Shown with Optional Goniometer



Multi-Antenna Dual-Ring Distributed-Axis Scanning Method
 Shown with Optional Dual Ring

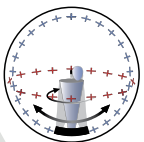

Multi-Antenna Dual-Ring Distributed-Axis Scanning Method
 Shown with Optional Dual Ring and Optional Goniometer

Typical TRP Test Times (in minutes, per frequency)

Test Configuration	4G	5G (FR1)
Stepped	<2 min	<2 min
Spiral	<2 min	<2 min

Path Lengths (nominal)

Model	Path Length
AMS-8923-080	0.80 m path length
AMS-8923-135	1.35 m path length
AMS-8923-150	1.50 m path length
AMS-8923-195	1.95 m path length
AMS-8923-317	3.17 m path length

An optional MIMO ring can be added to include all capabilities of the AMS-8700 MIMO OTA solution (see photo left and below). This chamber can also be configured with a chair assembly to conduct measurements with a full body phantom or real person for wearable device performance.

Some AMS-8923 models can be upgraded to contain 47 antennas on the SISO ring, providing 7.5 degree sampling resolution rather than 15 degrees when using 23 antennas. Additionally, a goniometer system is optional for either the AMS-8923 or AMS-8947 to further enhance the sampling resolution of the 3D pattern that can be measured.

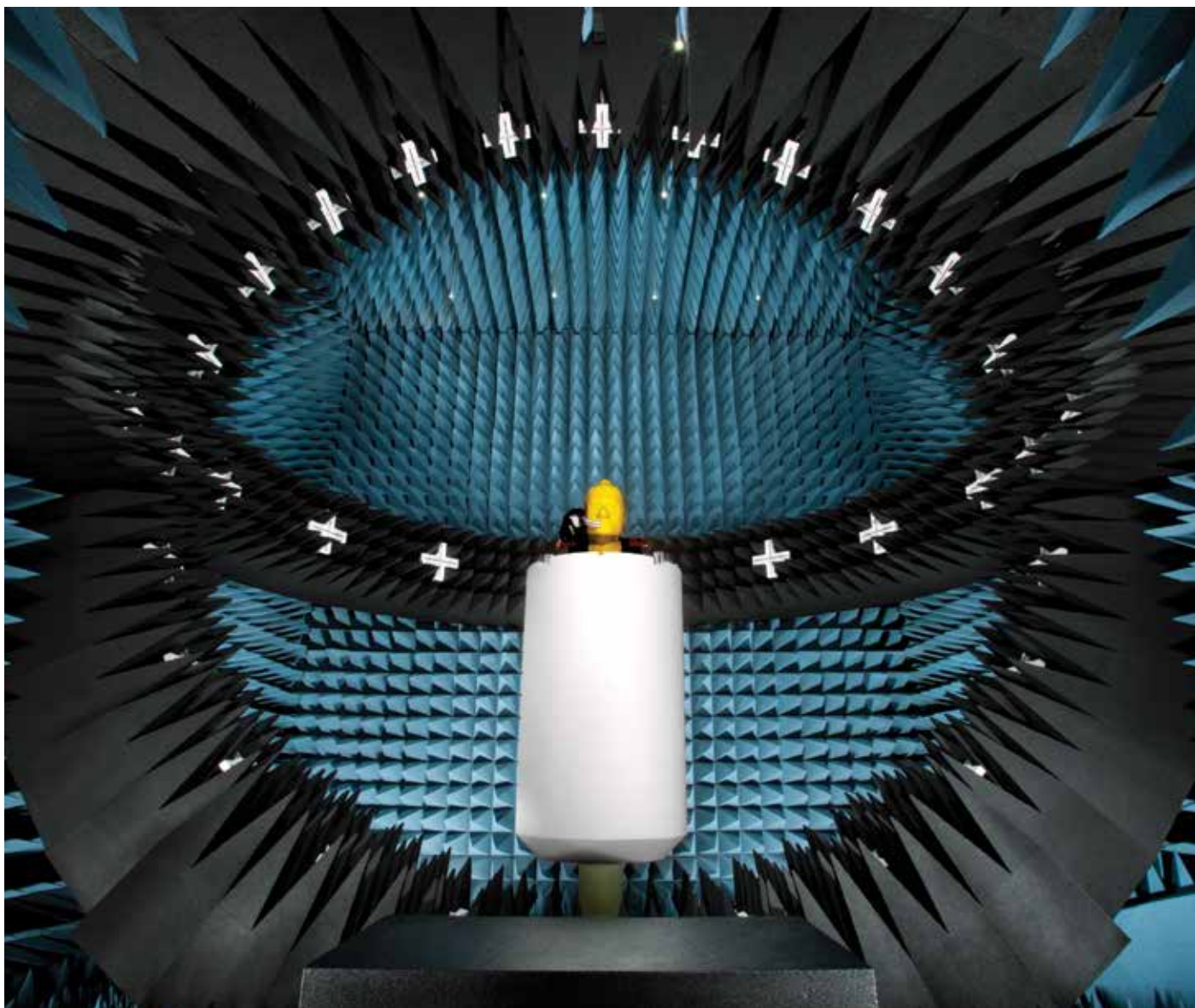





AT A GLANCE: mmWAVE TEST SYSTEMS



	AMS-5700	AMS-5701	AMS-5702	AMS-5703
Target/Optimum Application	Manufacturing QA, Receiver/Transmitter Calibration, 2D or Fixed Beam Applications	5G Conformance and Performance Testing (EIRP, TRP, EIS, TIS), Radio Interoperability	5G Conformance and Performance Testing (EIRP, TRP, EIS, TIS), Radio Interoperability. Flexible System with Variable Path Length to Adjust for Wide Range of Array Sizes and Optimized Dynamic Range	5G Conformance and Performance Testing (EIRP, TRP, EIS), Radio Interoperability, TX and RX Beam-Peak Search, TX and RX CCDF
Description	Azimuth Axis Antenna Measurement System	Distributed-Axis Antenna Measurement System	Combined-Axis Antenna Measurement System	Compact Range (CATR), Combined-Axis Antenna Measurement System
Typical Test Device Type	Module, Phone	Module, Phone	Module, Phone	Phone, Tablet, Small Cells, CPE, Laptop, gNB Base Station
Compliance Standard/Technology	R&D	3GPP	3GPP	3GPP/CTIA, Qualcomm
Frequency Range	5G FR2 / 24 GHz to 44 GHz, 5 GHz to 50 GHz	5G FR2 / 24 GHz to 44 GHz, 6 GHz to 67 GHz	5G FR2 / 24 GHz to 44 GHz, 5 GHz to 50 GHz	18 GHz to 50 GHz, Upgradeable Outside of this Frequency Range
Physical Format	Tabletop	Mobile/Wheels	Mobile/Wheels	Chamber/Non-Mobile
Testing Methodology	Direct Far-Field (DFF)	Direct Far-Field (DFF)	Direct Far-Field (DFF)	Indirect Far-Field (IFF)
Rotation Axis	Single-Axis Turntable Upgradeable for 3D	Single-Axis Turntable with Theta-Arm (Spherical)	Dual-Axis Positioner (Spherical) with Variable Range Length Linear Slide	Dual-Axis Positioner (Spherical)
Maximum Antenna Array Size	24 GHz = 7.8 cm 28 GHz = 7.2 cm 39 GHz = 6.2 cm 44 GHz = 5.8 cm	24 GHz = 6.8 cm 28 GHz = 6.2 cm 39 GHz = 5.2 cm 44 GHz = 5.0 cm	24 GHz = 5.6 cm - 9.6 cm 28 GHz = 5.0 cm - 8.8 cm 39 GHz = 4.4 cm - 7.6 cm 44 GHz = 4.0 cm - 7.0 cm	24 GHz = 60.0 cm 28 GHz = 60.0 cm 39 GHz = 60.0 cm 44 GHz = 60.0 cm
Exterior Chamber Nominal Size	1.5 m x 0.7 m x 0.9 m (4.9 ft x 2.3 ft x 3.0 ft)	2.1 m x 1.4 m x 2.2 m (6.9 ft x 4.6 ft x 7.2 ft)	2.5 m x 1.4 m x 1.8 m (8.2 ft x 4.6 ft x 5.9 ft)	4.6 m x 2.7 m x 2.4 m (15.0 ft x 9.0 ft x 8.0 ft)

The AMS-5700 tabletop enclosure is suitable for manufacturing QA, receiver/transmitter calibration, and 2D or fixed-beam applications. Solution is upgradeable for 3D measurements.



AMS-5704	AMS-5705 	AMS-5706 	AMS-5707 	AMS-5708 	AMS-5709 
60 GHz Device/Antenna Performance Testing	5G Conformance and Performance Testing (EIRP, TRP, EIS), Radio Interoperability, TX and RX Beam-Peak Search, TX and RX CCDF	5G Conformance and Performance Testing (EIRP, TRP, EIS), Radio Interoperability, TX and RX Beam-Peak Search, TX and RX CCDF	5G Conformance and Performance Testing (EIRP, TRP, EIS), Radio Interoperability, TX and RX Beam-Peak Search, TX and RX CCDF	5G Conformance and Performance Testing (EIRP, TRP, EIS), Radio Interoperability, TX and RX Beam-Peak Search, TX and RX CCDF	5G FR2 MIMO Conformance, Performance Testing (EIRP, TRP, EIS), Radio Interoperability, TX and RX Beam-Peak Search, TX and RX CCDF
Distributed-Axis Antenna Measurement System	Compact Range (CATR), Combined-Axis Antenna Measurement System	Compact Range (CATR), Combined-Axis Antenna Measurement System	Compact Range (CATR), Combined-Axis Antenna Measurement System	Compact Range (CATR), Combined-Axis Antenna Measurement System	Combined-Axis MIMO Antenna Measurement System
Module, Phone, Computer Peripherals	Module, Phone, Tablet, Small Cells	Phone, Tablet, Small Cells, Laptop	Phone, Tablet, Small Cells, CPE, Laptop, gNB Base Station	Phone, Tablet, Small Cells, CPE, Laptop, gNB Base Station	Phone, Tablet
WiGig, 802.11ad, 802.11ay	3GPP/CTIA, Qualcomm	3GPP/CTIA	3GPP/CTIA	3GPP/CTIA	3GPP/CTIA
6 GHz to 67 GHz	5G FR2 / 24 GHz to 44 GHz	5G FR2 / 24 GHz to 44 GHz	18 GHz to 50 GHz, Upgradeable Outside of this Frequency Range	18 GHz to 50 GHz, Upgradeable Outside of this Frequency Range	5G FR2 / 24 GHz to 44 GHz
Mobile/Wheels	Mobile/Wheels	Mobile/Wheels	Chamber/Non-Mobile	Chamber/Non-Mobile	Mobile/Wheels
Direct Far-Field (DFF)	Indirect Far-Field (IFF)	Indirect Far-Field (IFF)	Indirect Far-Field (IFF)	Indirect Far-Field (IFF)	Direct Far-Field (DFF)
Single-Axis Turntable with Theta-Arm (Spherical)	Dual-Axis Positioner (Spherical)	Dual-Axis Positioner (Spherical)	Dual-Axis Positioner (Spherical)	Dual-Axis Positioner (Spherical)	Dual-Axis Positioner (Spherical)
50 GHz = 4.7 cm 60 GHz = 4.3 cm 70 GHz = 4.0 cm 75 GHz = 3.8 cm	24 GHz = 30.0 cm 28 GHz = 30.0 cm 39 GHz = 30.0 cm 44 GHz = 30.0 cm	24 GHz = 45.0 cm 28 GHz = 45.0 cm 39 GHz = 45.0 cm 44 GHz = 45.0 cm	24 GHz = 100.0 cm 28 GHz = 100.0 cm 39 GHz = 100.0 cm 44 GHz = 100.0 cm	24 GHz = 150.0 cm 28 GHz = 150.0 cm 39 GHz = 150.0 cm 44 GHz = 150.0 cm	24 GHz = 20.0 cm 28 GHz = 20.0 cm 39 GHz = 20.0 cm 44 GHz = 20.0 cm
2.1 m x 1.4 m x 2.2 m (6.9 ft x 4.6 ft x 7.2 ft)	2.7 m x 1.5 m x 2.0 m (8.8 ft x 5.0 ft x 6.5 ft)	4.0 m x 2.0 m x 2.4 m (13.1 ft x 6.6 ft x 7.9 ft)	8.5 m x 4.9 m x 4.0 m (28.0 ft x 16.0 ft x 13.0 ft)	10.7 m x 5.5 m x 5.5 m (35.0 ft x 18.0 ft x 18.0 ft)	Approx. 0.9 m x 1.3 m x 1.8 m (2.9 ft x 4.3 ft x 6.0 ft)



The AMS-5703 is ideal for 5G FR2 conformance and performance testing (EIRP, TRP, EIS, TIS), as well as radio interoperability testing.

5G FR2 TEST SYSTEMS

AMS-5700 COMPACT 5G ANTENNA MEASUREMENT SYSTEM

Measurement frequency range: 5 GHz to 50 GHz

Portable desktop unit for supporting multiple applications and groups

ETS-Lindgren's AMS-5700 is a compact 2D antenna performance measurement system that offers versatility in application and frequency range. The compact direct far-field design allows short cables and optimum instrumentation placement near the measurement antenna. AUT administration is achieved through a wide opening door and various DC, communication, and RF connectors that can be mounted to the feed-through panel. Additionally, AMS-5700 is a tabletop design that can be moved by cart between floors to be shared among labs and moved in most elevators. An optional roll-axis stage can be fitted to this model to enable 3D patterns on light antennas and arrays. This model is recommended for universities, R&D, design validation, pre-certification testing, and small-antenna passive 2D or 3D performance metrics.

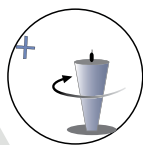

Azimuth Axis Scanning Method



**Combined-Axis Scanning Method
(Available as Upgrade)**

Electrical Specifications

	Specs
Measurement Frequency Range	5 GHz to 50 GHz standard, options up to 110 GHz
Path Length	≈ 1.0 m
Azimuth Positioner	Accuracy: 0.03 deg Resolution: 0.01 deg
Quiet Zone Size (Maximum Antenna Under Test Diameter per Frequency)	At 20 GHz ~8 cm At 40 GHz ~6 cm At 60 GHz ~4 cm
Typical RF Isolation	80 dB @ 40 GHz

AMS-5701 mmWAVE ANTENNA PATTERN MEASUREMENT SYSTEM

Measurement frequency range: 6 GHz to 67 GHz

Maximum frequency and application flexibility for mmWave antenna testing

ETS-Lindgren's AMS-5701 is a distributed-axis spherical-pattern antenna measurement system with a highly flexible application and frequency range. Passive and active antenna pattern tests are supported using an easy-to-fixture azimuth base with high accuracy and repeatability. Path losses are minimized with this design by placing components as close to the measurement antenna as possible. This chamber offers a 82 cm x 144 cm (32 in x 56 in) 160° swing door that allows full access to the internal volume of the chamber. AMS-5701 is a roll-in-place chamber that can move between floors, down hallways, and through standard doorways when the removable ceiling section is unbolted. Antennas of nearly any size and shape can be accommodated on the azimuth base, and cabling can be fixed to the mounting column as the test article requires. The AMS-5701 is well-suited for universities and R&D labs where immediate feedback is needed on early designs or revisions.



Theta-Arm
Distributed-Axis
Scanning Method

Electrical Specifications

	Specs
Measurement Frequency Range	6 GHz to 67 GHz
Path Length	75 cm
Azimuth Positioner	Accuracy: 0.05 deg Resolution: 0.02 deg
Max. DUT Weight	5 kg (11 lb)
Quiet Zone Size (Maximum Antenna Under Test Diameter per Frequency)	At 20 GHz ~7 cm At 40 GHz ~5 cm At 60 GHz ~4 cm
Typical RF Isolation	80 dB @ 40 GHz
Assembly Information	Shipped in 3 Sections, on Casters, Assembled on Site

5G FR2 Typical Test Time, 7.5 deg Resolution (in minutes, per frequency)

Test Target	Minutes
TRP	30
CDF	240
CDF-RX	360

AMS-5702 5G ANTENNA MEASUREMENT SYSTEM (3D)

Measurement frequency range: 5 GHz to 50 GHz

Precision device-positioning and variable measurement range

ETS-Lindgren’s AMS-5702 is a combined-axis far-field measurement test system that provides 3D radiated performance measurements of 5G mmWave wireless devices. This model offers precise device positioning with hundredths of a degree resolution and reproducibility. The AMS-5702 excels in 5G FR2 “white-box” applications where the transmitting antenna characteristics and location are known and test data is required quickly. The RF shielded anechoic enclosure is mobile (on wheels) for sharing among design groups or lab areas. This model also incorporates a linear slide that allows path length optimization between the AUT and probe antenna. Larger antenna arrays can be tested with the increased path length, and for smaller antenna diameters the measurement antenna is moved closer to the DUT to improve the dynamic range of the system. Accommodating antenna array diameters up to 10 cm at 20 GHz and 7 cm at 44 GHz, AMS-5702 covers the vast majority of FR2 transmitting devices, especially with “white-box” knowledge of the device.

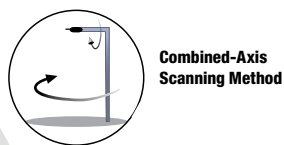

Combined-Axis Scanning Method

Electrical Specifications

	Specs
Measurement Frequency Range	5 GHz to 50 GHz Standard
Path Length	Variable, 50 cm to 150 cm
Device Positioner	Accuracy: 0.05 deg Resolution: 0.02 deg
Quiet Zone Size (Maximum Antenna Under Test Diameter per Frequency)	24 GHz = 5.6 cm - 9.6 cm 28 GHz = 5.0 - 8.8 cm 39 GHz = 4.4 cm - 7.6 cm 44 GHz = 4.0 cm - 7.0 cm
Typical RF Isolation	80 dB @ 40 GHz

5G FR2 Typical Test Time, 7.5 deg Resolution (in minutes, per frequency)

Test Target	Minutes
TRP	30
CDF	240
CDF-RX	360

AMS-5703 5G CATR ANTENNA MEASUREMENT SYSTEM

Measurement frequency range: 18 GHz to 50 GHz

60 cm quiet zone CATR capability for all FR2 devices

ETS-Lindgren's AMS-5703 is our most popular compact antenna test range (CATR) thanks to its 60 cm QZ and heavy-duty positioning system. This chamber is a favored do-it-all system that handles everything from smart phones to gNodeB base stations comfortably within the QZ. Labs wishing to offer antenna and transmitter testing for the coming wave of FR2 O-RAN base stations, repeaters, and distribution systems will appreciate the 50 kg (110 lb) positioning capacity for the DUT this model offers. AMS-5703 features a walk-in chamber design with plenty of space to mount, cable, and prepare complex DUTs for testing. AMS-5703 meets the 3GPP and CTIA quality-of-quiet-zone test method as well as phase validation requirements for 5G NR bands n257 through n262. Model AMS-5703 is also approved by Qualcomm for FR2 beam characterization and verification measurements. As opposed to 30 cm quiet zone CATRs, AMS-5703's larger QZ allows combinations of devices, phantoms, and materials to be characterized for a much better understanding of real world device performance.

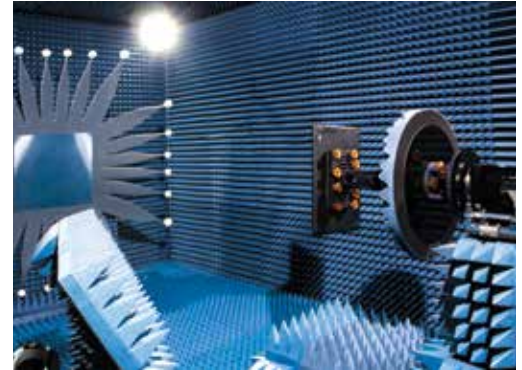

5G *Meets 3GPP requirement for 5G.*
Contact your ETS-Lindgren representative for details.



Electrical Specifications

	Specs
Measurement Frequency Range	5G NR FR2, 18 GHz to 50 GHz
Device Positioner	Accuracy: 0.03 deg Resolution: 0.01 deg
Quiet Zone Size	60 cm Diameter Cylinder, 60 cm in Depth
Typical RF Isolation	80 dB @ 40 GHz
Antenna Under Test Max Weight	30 kg (66 lb), Optional 50 kg (110 lb)

5G FR2 Typical Test Time, 7.5 deg Resolution (in minutes, per frequency)

Test Target	Minutes
TRP	30
CDF	240
CDF-RX	360

AMS-5704 WiGig ANTENNA MEASUREMENT SYSTEM

Measurement frequency range: 6 GHz to 67 GHz

WiGig chamber with high-accuracy and repeatable testing

ETS-Lindgren’s AMS-5704 is a distributed-axis spherical-pattern antenna measurement system that targets the WiGig frequency range. Passive and active antenna pattern tests on WiGig (802.11ay and 802.11ad) devices are supported with high accuracy and repeatability. Path losses are minimized with this design by placing components as close to the measurement antenna as possible. This chamber offers an approximately 160-degree swing door that allows full access to the internal volume of the chamber. AMS-5704 is a roll-in-place chamber that can move between floors, down hallways, and through standard doorways when the removable ceiling section is unbolted. Devices can be placed on the azimuth base with little or no fixture needed, and cabling can be fixed to the azimuth column as the test article requires.



**Theta-Arm
Distributed-Axis
Scanning Method**

Electrical Specifications

	Specs
Measurement Frequency Range	6 GHz to 67 GHz / 802.11ad / 802.11ay
Path Length	≈ 75 cm
Azimuth Positioner	Accuracy: 0.05 deg Resolution: 0.02 deg
Elevation Positioner	Accuracy: 0.05 deg Resolution: 0.02 deg
Quiet Zone Size (Maximum Antenna Under Test Diameter per Frequency)	At 6 GHz ~13.7 cm At 24 GHz ~6.8 cm At 39 GHz ~5.4 cm At 67 GHz ~4.1 cm
Typical RF Isolation	80 dB @ 40 GHz

AMS-5705 5G CATR ANTENNA MEASUREMENT SYSTEM

Measurement frequency range: 24 GHz to 43.5 GHz

30 cm quiet zone CATR for FR2 devices

ETS-Lindgren's AMS-5705 is an indirect far-field compact antenna test range (CATR) system with a 30 cm QZ. The system meets 3GPP and CTIA quality-of-quiet-zone and phase-validation requirements for 5G NR bands n257 through n262. AMS-5705 is also Qualcomm approved for FR2 beam characterization and verification. Its 30 cm QZ is perfect for 5G FR2-enabled smartphone and tablet testing with CTIA approved phantoms.

This model offers 10 kg (22 lb) positioning capacity for the DUT and necessary FR2 phantoms, and provides USB for device communication and power on the multi-axis positioning system (MAPS). AMS-5705 is a reach-in semi-portable chamber design on casters that can be relocated as needed through common double-door width office space. This system also supports passive antenna-pattern testing for any antenna array up to 30 cm diameter in the listed frequency range.

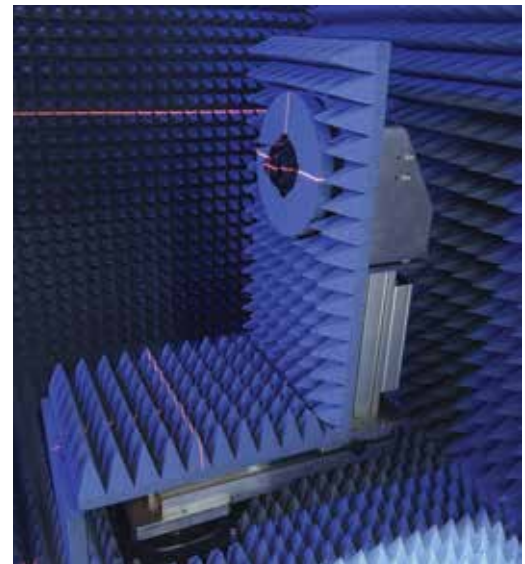

An optional climatic dome can be mounted to the MAPS to enclose devices for performance testing while temperature cycling. 3GPP and other standards may require temperature cycling for 5G FR2 devices that can be installed outdoors or in areas without temperature control measures.

5G *Meets 3GPP requirement for 5G.*
Contact your ETS-Lindgren representative for details.

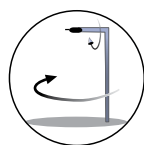

Combined-Axis Scanning Method

Electrical Specifications

	Specs
Measurement Frequency Range	5G NR FR2, 24 GHz to 43.5 GHz
Device Positioner	Accuracy: 0.05 deg Resolution: 0.01 deg
Quiet Zone Size	30 cm Diameter Cylinder, 30 cm in Depth
Typical RF Isolation	80 dB @ 40 GHz
Antenna Under Test Max Weight	10 kg (22 lb)

5G FR2 Typical Test Time, 7.5 deg Resolution (in minutes, per frequency)

Test Target	Minutes
TRP	30
CDF	240
CDF-RX	360

AMS-5706 5G CATR ANTENNA MEASUREMENT SYSTEM

Measurement frequency range: 24 GHz to 43.5 GHz

45 cm quiet zone CATR for FR2 devices

ETS-Lindgren’s AMS-5706 is a reach-in indirect far-field compact antenna test range (CATR) with a 45 cm QZ. This system is built with a unique approach that slots between a permanent built-in-place chamber, such as our AMS-5703, and a portable chamber, such as our AMS-5705. AMS-5706 utilizes multiple segments small enough to roll through standard doorways, hallways, and elevators found in a typical office or lab. Seven segments are bolted together, and, once in place, form the final structure. The 45 cm QZ targets larger form-factor devices like small-cell base stations, consumer premises equipment, and signal repeaters, along with any CTIA approved phantoms or materials that might prove useful in testing user experience for 5G FR2-capable devices. DUT positioning is handled by a multi-axis positioning system capable of handling 10 kg (22 lb).



An optional climatic dome can be mounted to the MAPS to enclose devices for performance testing while temperature cycling. 3GPP and other standards may require temperature cycling for 5G FR2 devices that can be installed outdoors or in areas without temperature control measures.

5G *Meets 3GPP requirement for 5G.*
Contact your ETS-Lindgren representative for details.

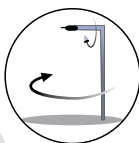

Combined-Axis Scanning Method

Electrical Specifications

	Specs
Measurement Frequency Range	5G NR FR2 Passive and Active Antenna Pattern Tests, 24 GHz to 43.5 GHz
Device Positioner	Accuracy: 0.05 deg Resolution: 0.02 deg
Quiet Zone Size	45 cm Diameter Cylinder, 45 cm in Depth
Typical RF Isolation	80 dB @ 40 GHz
Device Under Test Max Weight	10 kg (22 lb)

5G FR2 Typical Test Time, 7.5 deg Resolution (in minutes, per frequency)

Test Target	Minutes
TRP	30
CDF	240
CDF-RX	360

AMS-5707 CATR ANTENNA MEASUREMENT SYSTEM

Measurement Frequency Range: Variable Depending on Application

100 cm QZ CATR for military, aerospace, satellite and 5G FR2

ETS-Lindgren's AMS-5707 is a walk-in indirect far-field CATR with a 100 cm QZ. This chamber can be configured for various measurement frequency ranges specific to the transceiver and antenna system under test. Featuring a heavy-duty DUT positioner with 100 kg (220 lb) weight handling, this CATR is perfect for 5G FR2 base stations, repeaters, and distribution systems. AMS-5707 provides a noteworthy working space around the DUT positioner for mounting, setup, and administration of the test article. Its 100 cm QZ allows for phantoms and materials to be utilized during testing to characterize measurement conditions other than free space. The larger interior working volume can also accommodate taller RF absorber material for high-power transmitter applications. This large-volume CATR is perfect for full characterization of beam steering and adaptive antenna systems.

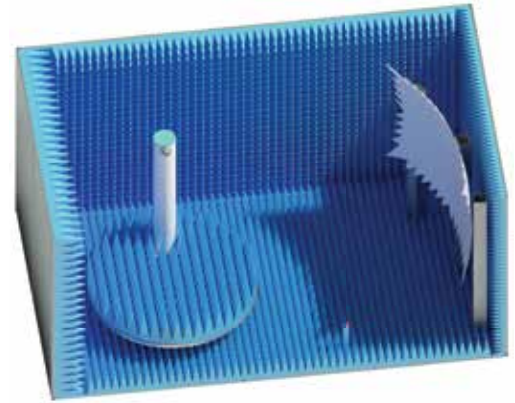

5G *Meets 3GPP requirement for 5G.*
Contact your ETS-Lindgren representative for details.

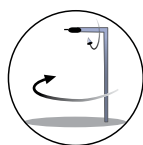

Combined-Axis Scanning Method

Electrical Specifications

	Specs
Measurement Frequency Range	Varies According to Application
Device Positioner	Accuracy: 0.05 deg Resolution: 0.01 deg
Quiet Zone Size	100 cm Diameter
Load Capacity	100 kg (220 lb)

AMS-5708 5G CATR ANTENNA MEASUREMENT SYSTEM

Measurement frequency range: Variable depending on application

150 cm quiet zone CATRs for military, aerospace, satellite, and 5G FR2

ETS-Lindgren's AMS-5708 is a walk-in indirect far-field compact antenna test range (CATR) with a 150 cm QZ. Flexible in its design, the AMS-5708 can be configured for various measurement frequency ranges specific to the transceiver and antenna system under test. This CATR features a heavy-duty DUT positioner with 100 kg (220 lb) weight handling, perfect for 5G FR2 base stations, repeaters, and distribution systems. The AMS-5708 provides a noteworthy working space around the DUT positioner for mounting, setup, and administration of the test article. Its 150 cm QZ allows for phantoms and materials to be utilized during the tests to characterize measurement conditions other than free space. The larger interior working volume can also accommodate taller RF absorber material for high-power transmitter applications. This large-volume CATR is perfect for full characterization of beam steering and adaptive antenna systems.

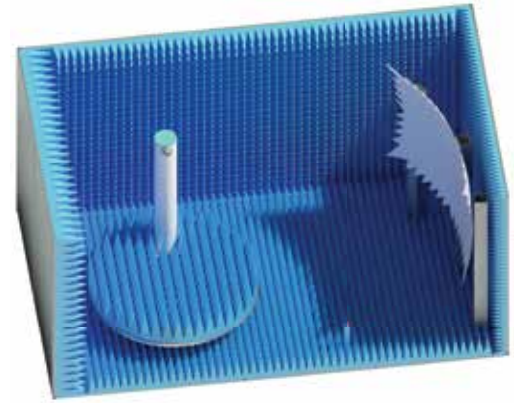

5G *Meets 3GPP requirement for 5G.*
Contact your ETS-Lindgren representative for details.

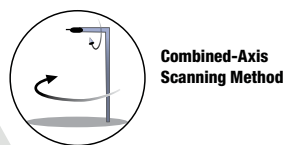

Electrical Specifications

	Specs
Measurement Frequency Range	Varies According to Application
Device Positioner	Accuracy: 0.05 deg Resolution: 0.01 deg
Quiet Zone Size	150 cm Diameter
Load Capacity	100 kg (220 lb)

AMS-5709 5G MIMO ANTENNA MEASUREMENT SYSTEM

Measurement frequency range: 5 GHz to 50 GHz

Multi-probe system for FR2 MIMO tests

ETS-Lindgren's AMS-5709 is a 5G FR2 MIMO transceiver performance validation system for CTIA test methods. It houses a measurement antenna array cluster, multi-axis 3D device positioner, and laser-alignment tool to accurately position the device. This compact reach-in design is portable and specially designed to move through common hallway and door openings, making it ideal for R&D, as well as certification labs. The 20 cm QZ and device positioner are accessible through a wide-opening door, allowing easy administration of the DUT. FR1 and FR2 communication antennas are placed to ensure a stable link communication in stand-alone (SA) and non-standalone modes (NSA). When combined with EMQuest Software and FR2 signaling instrumentation, this high-accuracy system fulfills the CTIA FR2 MIMO OTA requirements using a direct far-field test method.



5G *Meets 3GPP requirement for 5G.*
Contact your ETS-Lindgren representative for details.



Electrical Specifications

	Specs
Measurement Frequency Range	5G FR2 MIMO Tests 5 GHz to 50 GHz
Device Positioner	Accuracy: 0.1 deg Resolution: 0.02 deg
Quiet Zone Size	20 cm Diameter Sphere
Typical RF Isolation	80 dB @ 40 GHz
Device Under Test Max Weight	2 kg (4.4 lb)

WIRELESS COMPONENTS

In addition to being the leader in test systems, ETS-Lindgren is also the leader in wireless components. From Shielding to Antennas and beyond, we offer a wide selection of components to complete your test lab. If your testing requires a specialized solution, we have the ability to design and produce exactly what you require.

SHIELDING, SHIELDED TEST ENCLOSURES, AND SHIELDED DOORS

We are the proven experts in shielding, with over 50,000 shielded enclosures installed worldwide. As the in-house manufacturer of Series-81 and Series-101 shielding, we ensure that all ETS-Lindgren Shielding meets our stringent performance demands. We use this same expertise on all of our Test Enclosures, from our tabletop models to large shielded enclosures. We also have a wide variety of standard shielded doors that we can customize to meet your specific requirements as needed.





RF MICROWAVE ABSORBER

ETS-Lindgren is also the in-house manufacturer of the RF Microwave Absorber material we use. Workstations running advanced numerical modeling software are used to develop our absorber products, which are then prototyped and tested to validate predicted results. Absorber Solutions include materials for walls, ceilings, and walkways. Custom Solutions are also available.

POSITIONING SYSTEMS

With ETS-Lindgren's Positioning Systems, AUTs can be repeatedly positioned within a fraction of a degree to capture the small intricacies of the antenna patterns. ETS-Lindgren's Single-Axis (2D-pattern) and Dual-Axis (3D-pattern) Positioners are designed to test a wide range of devices, from small chipset-size AUTs to large base station size AUTs. As an option, Positioners can be designed to allow control signals to pass through them which allows control of the AUT during the test as needed. For additional information, please visit our website.

MEASUREMENT AND REFERENCE ANTENNAS

ETS-Lindgren has a broad line of antennas suitable for all types of wireless testing. ETS-Lindgren's Antennas are considered industry benchmarks. From creating innovative designs that lead to standard development to defining antenna calibration procedures, ETS-Lindgren's experts produce antennas that can be trusted to produce measurements that are both accurate and repeatable.

PHANTOM HAND, PHANTOM HEAD, FULL BODY CHAIRS, AND DUT MOUNTS

ETS-Lindgren offers phantom head and hand kits to complete your test environment, including phantom hand only, phantom head only, and phantom head with integrated hand. We also manufacture multiple DUT mounts to accommodate your particular DUT.

CUSTOM COMPONENT SOLUTIONS

We understand our customers may have unique requirements not met by our standard solutions. For more information on our custom design capabilities, please visit our website or contact your local ETS-Lindgren representative.

WIRELESS SERVICES SOLUTIONS

From education to consultation and product tests to calibration, ETS-Lindgren has dedicated experts committed to our customers' success. ETS-Lindgren understands how downtime can impact our customers' development, production, and testing schedules. Let ETS-Lindgren assist in maintaining your chambers and training your employees to ensure optimal utilization of your assets.

ETS-Lindgren employs more than 800 professionals at locations in the Americas, Europe, the Middle East, and Asia. In addition, we have a global network of independent representatives and distributors. Our customers benefit with local service and support from specialists who are backed by ETS-Lindgren's global resources.

PRODUCT CALIBRATION AND REPAIR

Our A2LA-Accredited Calibration Laboratory (Lab Cert. #1207.01) is equipped with calibrated instrumentation traceable to National Metrology Institutes (NMI), several anechoic chambers, test cells, and a 80 m x 50 m (262 ft x 164 ft) welded steel ground plane for antenna calibration. ETS-Lindgren calibrates all brands of wireless antennas and often makes basic repairs when needed and pre-approved. Calibrations are accompanied with a signed certificate and can be supplied with correction factors (where applicable) in electronic format.





ENGINEERING AND CONSULTING

ETS-Lindgren has in-house experts to design integrated systems for wireless applications, design and manufacture custom components, perform site surveys (including EMI, vibration, and acoustic), and oversee project management. ETS-Lindgren also provides an assortment of design and site-planning services, including magnetic and RF shielding design, acoustic design, and Building Information Modeling (BIM).

FIELD SERVICES

ETS-Lindgren's Field Services consist of a global network of field installation teams and customer service personnel, all available for on-location services. These services include chamber maintenance and repair, positioner maintenance and repair, on-site chamber testing and calibration, as well as new employee training and retraining existing staff.

IN-HOUSE PRODUCT TESTING SERVICES

Wireless product testing is available at ETS-Lindgren's corporate headquarters in Cedar Park, Texas. In 2002, we became the first CTIA Authorized Test Lab (CATL) for mobile station OTA performance testing. We also offer A-GPS and MIMO testing.

REFURBISHMENT AND RELOCATION SERVICES

In addition to the aforementioned field services, ETS-Lindgren can help you move, upgrade, or refurbish your existing wireless chambers. This type of activity can often save you money and increase the return on your investment. Talk with our experts about how we can assist you in achieving your refurbishment/relocation project goals.

ETS-U EDUCATION SERVICES

From basic to more advanced topics, ETS-U offers classes for wireless OTA testing, in addition to Automotive, EMC, and MIL-STD. Our classes are taught by industry experts and offer our students a low student-to-teacher ratio, yielding an overall better learning experience for our attendees. A lab component offered with several ETS-U classes provides a unique opportunity for hands-on demonstration of the material presented.

Sales and Support Offices

UNITED STATES – TEXAS

Cedar Park, TX

+1.512.531.6400 Phone

+1.512.531.6500 Fax

info@ets-lindgren.com

UNITED STATES – ILLINOIS

Wood Dale, IL

+1.630.307.7200 Phone

+1.630.307.7571 Fax

info@ets-lindgren.com

UNITED STATES – WISCONSIN

Minocqua, WI

+1.715.356.2022 Phone

+1.715.356.2023 Fax

info@ets-lindgren.com

FINLAND

Eura

+358.2.8383.300 Phone

+358.2.8651.233 Fax

euinfo@ets-lindgren.com

CHINA

Beijing

+86(10)8273.0877 Phone

+86(10)8273.0880 Fax

china@ets-lindgren.com

JAPAN

Tokyo

+81.3.3813.7100 Phone

+81.3.3813.8068 Fax

japan@ets-lindgren.com

INDIA

Bangalore

+91.80.4341.8600 Phone

+91.80.4341.8611 Fax

indiainfo@ets-lindgren.com

SINGAPORE

Singapore

+65.6391.0026 Phone

+65.6291.7311 Fax

singapore@ets-lindgren.com

TAIWAN

Taipei

+886.2.27023389 Phone

+886.2.27023055 Fax

taiwan@ets-lindgren.com

**COMMITTED TO A SMARTER,
MORE CONNECTED FUTURE**

 **ETS·LINDGREN**[®]

An ESCO Technologies Company

ets-lindgren.com