

EVO Air

User Manual

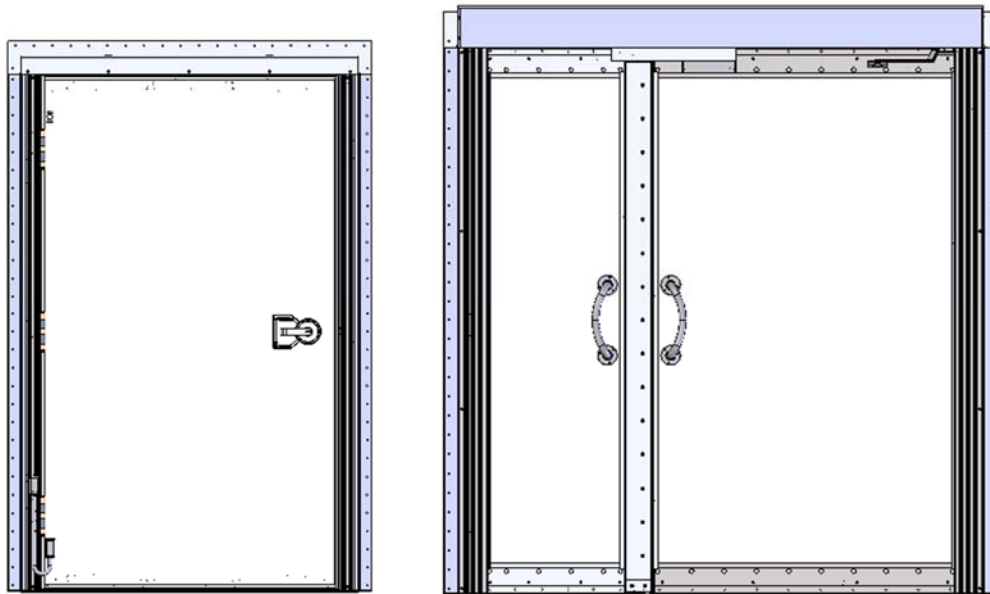

This page intentionally left blank.

ETS-Lindgren Inc. reserves the right to make changes to any products herein to improve functioning or design. Although the information in this document has been carefully reviewed and is believed to be reliable, ETS-Lindgren does not assume any liability arising out of the application or use of any product or circuit described herein; nor does it convey any license under its patent rights nor the rights of others. All trademarks are the property of their respective owners.

© Copyright 2018 by ETS-Lindgren Inc. All Rights Reserved. No part of this document may be copied by any means without written permission from ETS-Lindgren Inc.

Trademarks used in this document: The *ETS-Lindgren* logo is a registered trademark of ETS-Lindgren Inc; *Auto-Seal* is a trademark of ETS-Lindgren Inc; *3M* and *Scotch-Brite* are trademarks of 3M.

Revision Record

MANUAL,EVO Air | Part #1680788, Rev. A

Revision	Description	Date
A	Initial Release	July 2018

Table of Contents

Notes, Cautions, and Warnings	vi
Safety Information	vi
1.0 Introduction	7
2.0 Optional Equipment.....	9
Potential Configurations	9
EVO Air Keypad Door.....	9
Optional Items.....	10
Keypad	10
Air Supply	10
Maglock.....	10
Card Reader.....	10
Push Pad.....	10
Motion Sensor	10
IV Port	11
Blowout Door.....	11
Window	11
Customer Connections	11
Wiring Schematic.....	12
3.0 Operation.....	13
System Power.....	13
Seal / Unseal the Door (Standard)	14
Turn Off System Power	14
Lock/Unlock the Door (Standard)	14
Keypad, Card Reader, and Push Pad Operation	14
Double Door Operation.....	15
Customer Connections	15
4.0 Maintenance	17
Door System	17
Optional Air Compressor	17
Alternate Compressor.....	17
RF Seal Maintenance	17
Door Seal Replacement	18
Top and Bottom Seal	18
Latch and Hinge Side Seal	19

Appendix A: Warranty21

Notes, Cautions, and Warnings



Note: Denotes helpful information intended to provide tips for better use of the product.



CAUTION: Denotes a hazard. Failure to follow instructions could result in minor personal injury and/or property damage. Included text gives proper procedures.



WARNING: Denotes a hazard. Failure to follow instructions could result in SEVERE personal injury and/or property damage. Included text gives proper procedures.

Safety Information



Refer to Manual: When product is marked with this symbol, see the instruction manual for additional information. If the instruction manual has been misplaced, download it from ets-lindgren.com, or contact ETS-Lindgren Customer Service.



High Voltage: Indicates presence of hazardous voltage. Unsafe practice could result in severe personal injury or death.



High Voltage: Indicates presence of hazardous voltage. Unsafe practice could result in severe personal injury or death.



Protective Earth Ground (Safety Ground): Indicates protective earth terminal. You should provide uninterruptible safety earth ground from the main power source to the product input wiring terminals, power cord, or supplied power cord set.



Pinch Point: Indicates door should be kept clear when operating. Do not insert objects between seals and door. Unsafe practice could result in severe personal injury or door malfunction.

1.0 Introduction

The **ETS-Lindgren EVO Air** is a heavy-duty, all aluminum frame, and hollow metal door construction. For the two sides, the radio frequency (RF) seal is embedded in the jamb and expands toward the door by means of a pneumatically-driven mechanism. At the threshold the seal and mechanism are located on the top and bottom of the door. The expanded seal connects the door to the doorjamb. Doorjamb and shielded enclosure are also conductively fastened, thus effectively extending the shield across the door opening, preventing RF interference from entering or leaving the enclosure.

The electro-pneumatic method of operating the door is virtually maintenance-free. It allows operation of the door from either side. In the event of electrical or pneumatic failure the logic system automatically defaults to **Unseal** mode. The system is located inside the doorjamb. A power supply is located outside the room and supplies the door with power.

The power supply box also has other connections. That may be used to interconnect any customer indicator lamps or scan functions into the operation of the door. In addition to customer connections, there are also connections for an emergency pushbutton. See *Operations* on page 13 for more information.

The door requires an air compressor that may be included as an option or provided by the customer. The air supplied to the door must be dry and PSI regulated. 100 PSI is optimal, and 110 PSI is maximum.

This page intentionally left blank.

2.0 Optional Equipment



CAUTION: Before placing into operation, follow the information provided in *Safety Information* on page vi.



Note: If more wiring is needed than for standard doors, see wiring schematic on page 12 for details.

Potential Configurations

- Standard push pads on inside and outside of the room with a keyed switch by the control room for safety lock out.
- Optional keypad control on outside of room with a push pad on inside of room.
- Customer-provided card reader can be configured to control door from outside.
- Optional Safe IV Port (SIVP) on EVO Air door allows IV lines to be run through the jamb area to inside the room without being disconnected. –

EVO Air Keypad Door

An EVO Air Keypad Door is a standard door with the addition of a keypad. A door with a keypad system has several differences from a standard door.

- Uses a keypad to open the door from the outside and a handle to open from the inside.
- A power supply box is supplied with the door; it should be located at the equipment room.
- Connect air to the compressor first, and then to the door.
- If the door does not have an Automatic operator, enter the code before operating the door. See *Operation* on page 13 for more information. If the door has an Automatic operator, enter the code on the keypad to trigger the Automatic operator to open the door. Use the door handle to exit the room.



Note: Do not install emergency buttons near the keypad outside the room.

Optional Items

KEYPAD

See EVO Air Keypad Door on page 9.

AIR SUPPLY

A compressor with an auto-drain system is available upon request. See *Operation* on page 13 for more information regarding the integration of the air supply with the EVO Air system. If using another compressor, it must have an auto drain system or another method of keeping the air dry.

MAGLOCK

ETS-Lindgren can provide a maglock to act as a magnetic lock and an alternate security system for EVO Air Doors.



Note: This option is required for EVO Air Double doors and MUST be paired with either a Keypad or a Card Reader.

CARD READER

ETS-Lindgren can install a customer-supplied card reader for EVO Air Doors with and without an Automatic operator. If the EVO Air Door does not have an Automatic operator, swipe the card before operating the door. If the EVO Air Door has an Automatic operator, swipe the card to trigger the Automatic operator to open the door.

PUSH PAD

Push pads are available for EVO Air Doors with an Automatic operator and can be installed on the inside and/or outside of the chamber. To open the door, push the pad to trigger the Automatic operator.

MOTION SENSOR

Motion Sensors can only be installed on EVO Air Doors with an Automatic operator.



Note: The motion sensor is designed only to keep the door open by sensing if there is a presence in the doorway. The motion sensor is NOT designed to open the door for exit or entry.

IV PORT

An IV Port is available for EVO Air Single Doors. The IV Port is a specially designed port that allows IV lines to pass through the jamb without the need to disconnect the IV lines.

BLOWOUT DOOR

A blowout door is available upon request for In-Swing doors. The blowout door is a small hatch on the bottom of the EVO Air Door. In case of an emergency use the hatch as an emergency exit.

WINDOW

A 24" x 24" window is available as an option for EVO Air Doors.

Customer Connections

A dry contact from the PLC is allocated for customer usage. Two purple wires are connected to the contact and are brought out of the control box in a steel connection box. The contact is **NO** when the door is open and turns to **Closed** when the door closes.

Wiring Schematic

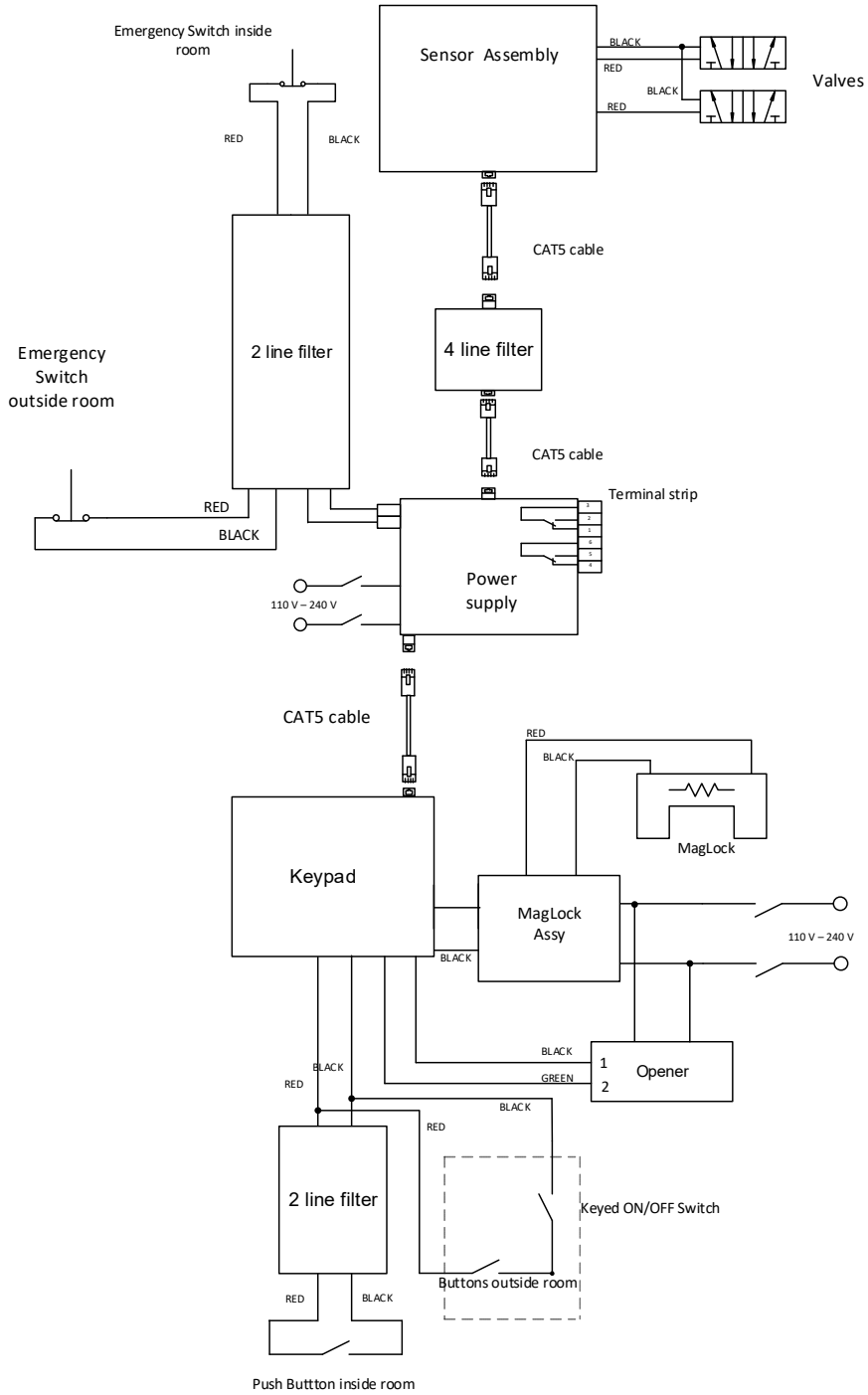

3.0 Operation



CAUTION: Before placing into operation, follow the information provided in *Safety Information* on page vi.

System Power



Note: Remove the top jamb cover to reach the door connections.

1. Connect electrical power to the system. Make sure the power supply is plugged into a 120 or 240 VAC power outlet, and then connect power to the door using a CAT-5E cable.
 - **In-Swing Door:** A CAT-5E connection runs from the power supply to the clean side of the filter, and from the filter to the inside of the jamb.
 - **Out-Swing Door:** The CAT-5E connection runs from the power supply to the inside of the jamb.
2. Connect air to the system using 1/4 inch tubing.
 - **In-Swing Door:** An air fitting is on the clean side of the filter. The other side of the fitting must be connected with the air connection inside the jamb.
 - **Out-Swing Door:** Connect the compressor output with the air connection inside the jamb.
3. Make sure the air supplied is clean, dry, and that the pressure is between 100 PSI and 110 PSI.

Closed doors will automatically seal when system power is initiated.



Note: Connect emergency system. Door will not operate without it.

Seal / Unseal the Door (Standard)

To seal the door: Swing the door to the closed position. Upon closing, a sensor activates the logic system and allows regulated pressurized air to enter the sealing system. The door will immediately seal. This process may be repeated from either side of the door.

To unseal the door: Turn the door handle and swing the door open. As the handle is turned, air pressure will exit the sealing system instantly, and the door can be opened without delay. This process can be repeated from either side of the door.

Turn Off System Power

To turn off the system, unplug the power supply. In cases where an emergency switch is installed, push the emergency switch. It will cut power to the power supply.

Pneumatic or electric doors will automatically unseal as soon as power is turned off.

Lock/Unlock the Door (Standard)

A classroom-type handle is used on each door and includes a lock. If the door is locked, no one can enter the room without the key; however, a person in the room may exit without the use of a key. Use the key provided to lock or unlock the door.

Without a power supply, the door defaults to a regular door. If it is locked, a key is required for entry.

Emergency buttons are to be installed inside the MRI room and the control room.

Keypad, Card Reader, and Push Pad Operation

To Enter the Room: In the following order, enter the code into the keypad, swipe the card in the card reader, and/or press the push button. If operating a manual door, turn the handle to open the door within 10 seconds of operating the device(s). The door will reseal if not opened during this window.

To Exit the Room: Turn the handle to open the door.



Note: In case of an emergency, push the red button to unseal the door. The emergency button will cut electrical power to the control system, causing the door to operate like a regular door. To reset the emergency button, turn it clockwise.

Double Door Operation

The EVO Air Double Door option is similar to the Single Door option except that it must include an Automatic operator. To open the door, operate the unlocking mechanism to trigger the Automatic operator. No other input is required.

Customer Connections

The customer connections are located on the power supply.

Two sets of dry connections are available. Set 1 has a **COM**, **NC**, and **NO** connection; Set 2 has similar connections.

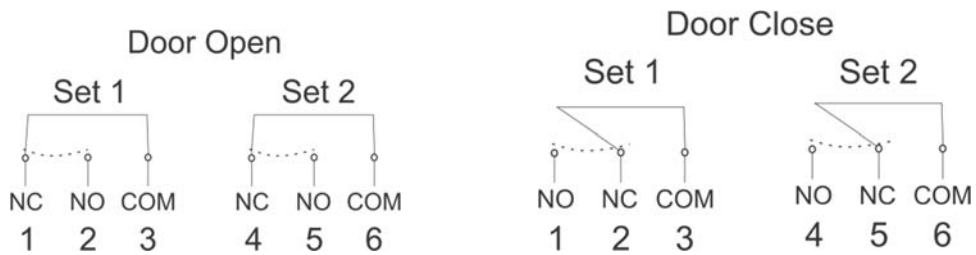
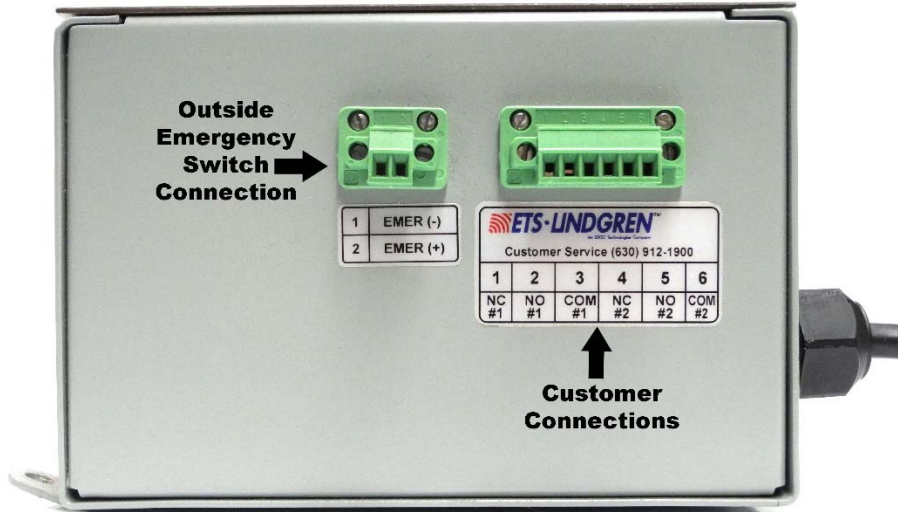

Next to the customer connections is the connection for an emergency switch. If an emergency switch is desired, remove the jumper and connect the emergency switch.

4.0 Maintenance



CAUTION: Before performing any maintenance, follow the information provided in *Safety Information* on page vi.

Door System



CAUTION: Do not sand the door seals.

CAUTION: Do not close the door with any obstructions across the threshold or in the door opening (power cords, etc.).

- Keep the stainless steel threshold clean and free of wax or floor polish. Make sure that the sides and top of the stainless steel door leaf are also clean.
- Use an abrasive sponge (similar to a 3M™ Scotch-Brite™ scouring pad) to clean the door and threshold where the seals make contact. The surfaces that can be sanded are the threshold, door top, and two door sides. Sand in the length direction.
- Use a clean cloth to wipe off the surfaces.



Note: For maximum performance, repeat this procedure monthly.

Optional Air Compressor

Check the level of water in the moisture collector and empty as needed. Repeat at least once a month, even though water may not reach the maximum level.

Alternate Compressor

If you supplied your own compressor, follow the manufacturer's recommended maintenance procedures.

RF Seal Maintenance

1. Using a soft rag and acetone or alcohol, clean all RF Seal contact areas to remove excess debris.
2. Using a soft sanding sponge (medium or fine), sand the entire RF Seal contact area.
3. Using a soft rag, wipe all RF Seal contact areas with acetone to remove any residue.

Door Seal Replacement

TOP AND BOTTOM SEAL

1. Remove all Cover Plate holder mounting screws and Cover Plate from the door.
2. Remove all RF Seal holder mounting screws and the RF Seal holder from the cartridge.
3. Remove used RF Seal and cut new RF Seal to match.



Note: To order material for new RF Seal, contact ETS-Lindgren, Inc.

4. Lightly sand the RF Seal mounting flange with a soft sanding sponge and wipe clean with a soft towel or rag.
5. Reinstall the RF Seal and RF Seal holder with the screws partially tightened. Adjust the RF Seal until the outer edge is flush with the end of the door and even with the Header and Threshold.
6. Once properly placed, tighten the RF Seal holder screws to secure the RF Seal.
7. Reinstall the cover plate.

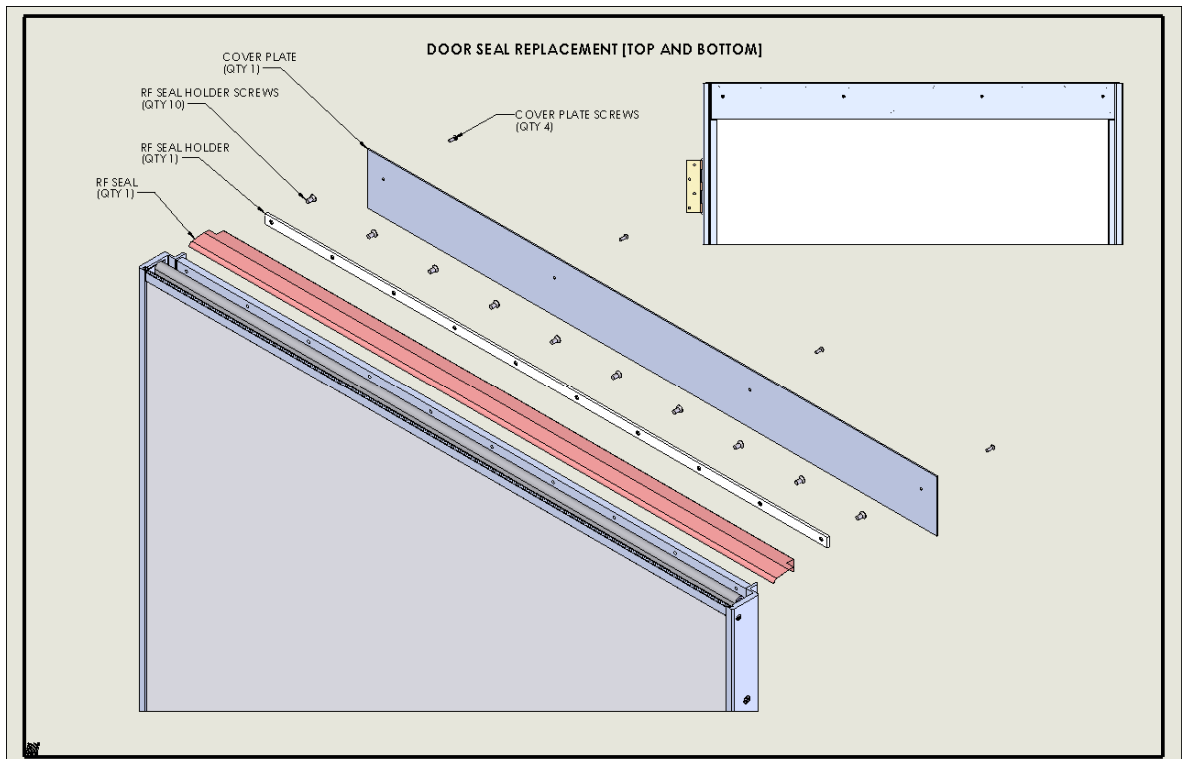

LATCH AND HINGE SIDE SEAL

1. Remove small Jamb Cover after removing the small jamb cover screws from the top and bottom of the cover.
2. Loosen all RF seal holder screws to loosen the RF Seal holder.
3. Remove used RF Seal and cut new RF Seal to match.



Note: To order material for new RF Seal, contact ETS-Lindgren, Inc.

4. Lightly sand RF Seal mounting flange with a soft sanding sponge and wipe clean with a soft towel or rag.
5. Reinstall RF Seal back into the jamb. Adjust the RF Seal until the outer edge is flush with the jamb cover and even with the Header and Threshold.
6. Once properly placed, tighten RF Seal holder screws to secure RF Seal.



Note: DO NOT wax the door threshold.

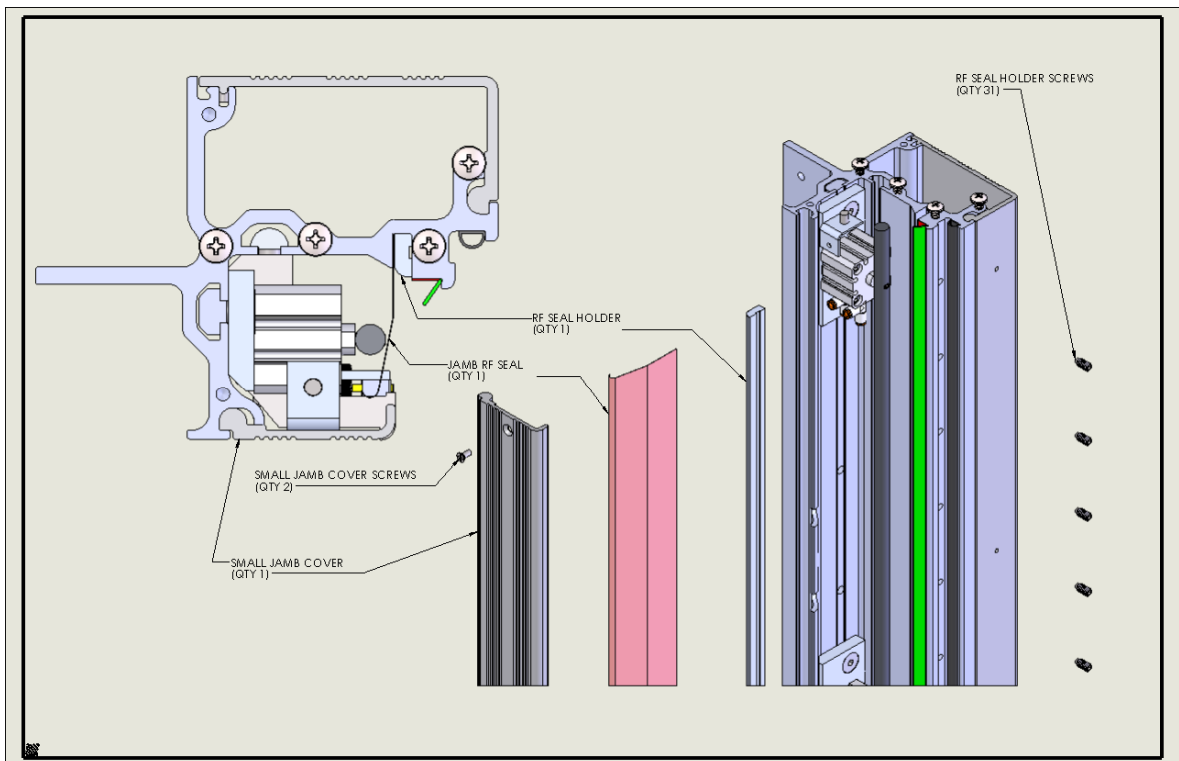

This page intentionally left blank.

Appendix A: Warranty



See the *Product Information Bulletin* included with your shipment for the complete ETS-Lindgren warranty for your EVO Air.

DURATION OF WARRANTIES FOR EVO AIR

All product warranties, except the warranty of title, and all remedies for warranty failures are limited to two years.

Product Warranted	Duration of Warranty Period
EVO Air Door	1 Year